

Climatic Control H&C

User Guide



INSTALLATION AND OPERATION MANUAL

ClimaticControl-HC Heating & Cooling Controller

IMPORTANT!

Before starting work the installer should carefully read this Installation & Operation Manual, and make sure all instructions contained therein are understood and observed.

ClimaticControl-HC should be mounted, operated and maintained by specially trained personnel only. Personnel in the course of training are only allowed to handle the product under the supervision of an experienced fitter. Subject to observation of the above terms, the manufacture shall assume the liability for the equipment as provided by legal stipulations.

All instructions in this Installation & Operation manual should be observed when working with the control. Any other application shall not comply with the regulations. The manufacturer shall not be liable in case of incompetent use of the control. Any modifications and amendments are not allowed for safety reasons. ClimaticControl-HC maintenance may be performed by service shops approved by the manufacturer only.

The functionality of the control depends on the model and equipment. This installation leaflet is part of the product and has to be obtained.

Subject to technical modification!

Table of content

<u>1.</u>	<u>Application.....</u>	<u>3</u>
<u>2.</u>	<u>References, Symbols and Abbreviations.....</u>	<u>3</u>
<u>3.</u>	<u>Safety Instructions.....</u>	<u>3</u>
<u>4.</u>	<u>Display.....</u>	<u>4</u>
<u>5.</u>	<u>Installation and Electrical connections.....</u>	<u>4</u>
5.1	ClimaticControl-HC Installation.....	4
5.2	Electrical connections.....	5
5.3	Hydraulic installation.....	6
5.4	Room Temperature – Direct Plug In.....	9
<u>6.</u>	<u>Types of operating modes / Program menu.....</u>	<u>14</u>
6.1	Heating and cooling switch.....	14
	There are several ways to switch the system between heating and cooling.....	14
•	Use parameter #0 Type (See Chap 7.1).....	14
•	Use the user interface of the Climatic Control HC if parameter #0 Type=Rev (See Chap 7.1).....	14
•	Use the user interface of the paired MILUX-RF HYGROSTAT if parameter #0 Type=Rev.....	14
•	Use Input 1 parameter #11 In1=HC or Input 2 parameter #12 In2 =HC (See Chap 5.4.7 and Chap 7.1).....	14
6.2	Types of operating modes.....	14
6.3	Program Mode.....	16
<u>7.</u>	<u>System Parameter Menu.....</u>	<u>18</u>
7.1	System parameters setting.....	18
7.2	Heating & Cooling curves.....	24
7.3	Corresponding value for sensors.....	24
<u>8.</u>	<u>Technical Data / Materials.....</u>	<u>24</u>
<u>9.</u>	<u>TROUBLE-SHOOTING.....</u>	<u>25</u>

1. Application

- ClimaticControl-HC is developed for variable flow temperature control in heating and cooling systems particular in low-temperature installations like floor heating and cooling systems. The flow temperature is controlled depending of the outside temperature following a curve.
- Using the ClimaticControl-HC the operation of a water floor system can be adapted to the actual demands of the system. In particular, the control can be used in apartments where users have their own individual living habits. A room temperature thermostat can also be connected. The control has a 7-day programmer including 9 factory set programs and 4 user defined programs.
- The control is normally used in conjunction with a hydraulic control unit which includes circulation pumps, a two- or three-way mixing valve and a valve actuator.
- The ClimaticControl-HC has been designed for use in dry environments, e.g. in residential rooms, office spaces and industrial facilities.
- Verify that the installation complies with existing regulations before operation to ensure proper use of the installation.

2. References, Symbols and Abbreviations

For better understanding in this document references are used in the form of symbols and abbreviations, which are described below.

➔	Reference to further documents	FIH	Floor heating
ⓘ	Important information and application hints	RaH	Radiant heating (general)
⚠	Safety information or Important information about functions	FRG	Hydraulic control unit with pump and mixing valve
Ⓞ	OK-button (OK)	HKV	Manifold
⏪	Control button Left (◀)	MuB	Installation and operation manual
⏩	Control button Right (▶)	TB	Temperature limiter
⊕	Plus button (+)	UWP	Circulation pump
⊖	Minus button (-)	WE	Boiler / heat generator

3. Safety Instructions



Before starting work disconnect power supply!

All installation and wiring work on the ClimaticControl-HC must be carried out only when de-energized. The appliance should be connected and commissioned by qualified personnel only. Make sure to adhere to valid safety regulations, in particular to VDE 0100 (German standard governing power installations of nominal voltages ≤ 1000 VAC).



The ClimaticControl-HC is neither splash, nor drip-proof. Therefore, they must be mounted at a dry place.



Do not interchange the connections of the sensors and the 230V connections under any circumstances! Interchanging these connections may result in life endangering **electrical hazards** or the destruction of the appliance and the connected sensors and other appliances.

4. Display

- 1: Operating modes
- 2: Keyboard is locked
- 3: Service Installation Menu
- 4: Manual operation / program override active (display of temperature offset)
- 5: a) display temperature (°C / °F)
b) display time (12 h / 24 h)
- 6: Type of temperature displayed
a) Water temperature
b) Outside temperature
c) Room temperature (if RF room thermostat connected)
- 7: Program graphic of the current day
 Comfort temperature
 Reduced temperature
- 8: Pump indicator
- 9: Demand indication
 Heating / Cooling / Humidity function
- 10: Current day of the week (1 = Monday; 7 = Sunday)
- 11: RF reception indicator (optional).
- 12: a) Symbol temperature indication in °C / °F
b) Symbol AM / PM if 12 h mode
- 13: a) Outside temperature (°C / °F)
b) Time (12 h / 24 h)
- 14: Mixing valve activity indicator
 Valve actuator is opening
 Valve actuator is closing

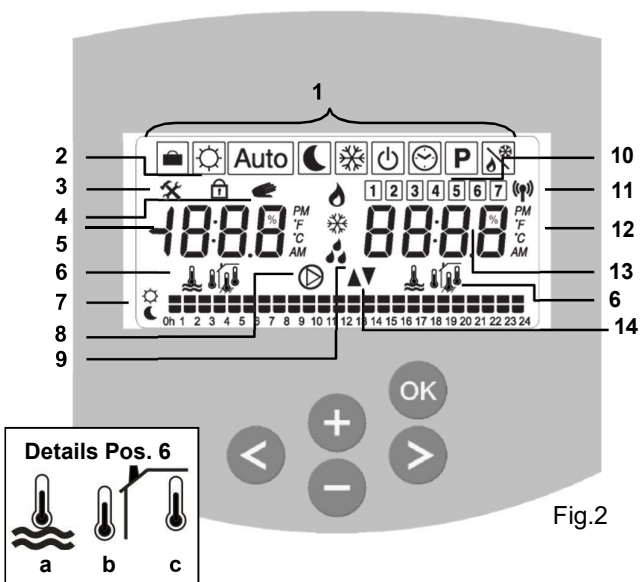

Fig.2

Dimensions

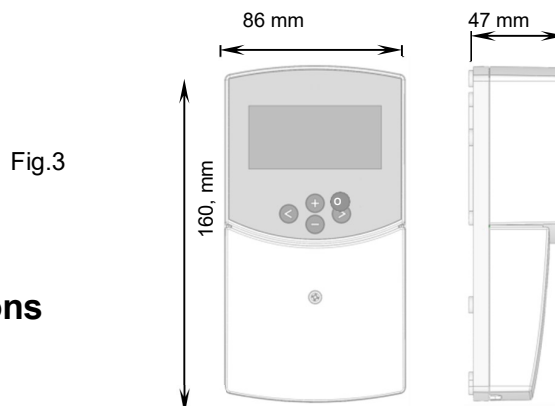

Fig.3

5. Installation and Electrical connections

5.1 ClimaticControl-HC Installation

The ClimaticControl-HC can be installed directly on a solid base (e.g. a wall). For this purpose the front panel of the ClimaticControl-HC must be removed (fig. 4a) and the back section should be fastened using appropriate screws and pins (these are not included in the scope of supply) (fig 4b) Fix the climatic control HC on a plane surface (wall...) If the ClimaticControl-HC has been factory fitted with cables for connecting to a pump, valve drive, temperature limiter, sensors etc., take care not to damage or crack the cables during the installation. Furthermore these cables should not be subjected to any tensile stress during installation. The cables will be fixed by means of the device for strain relief at the ClimaticControl-HC.

If the ClimaticControl-HC is delivered together with a hydraulic control unit (for example FRG or FlowBox) and if it is not attached to that unit by any installation plate or support, it should be installed next to that unit.

Pay attention to the correct connection of the cables if the ClimaticControl-HC is not installed directly on a hydraulic control unit but at some other place for the reason of better access.

Refer to the directions about this in section →5.2 Electric connections.

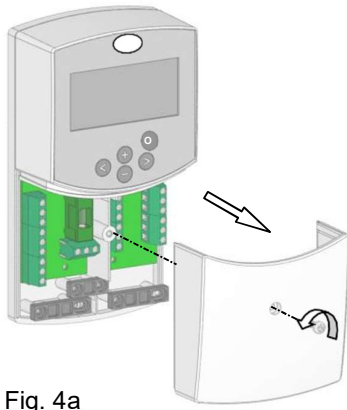

Fig. 4a

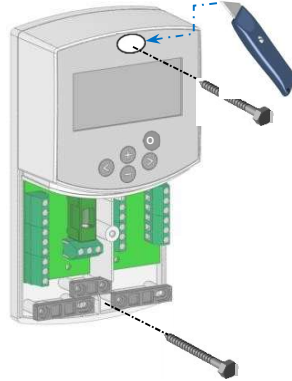

Fig. 4b

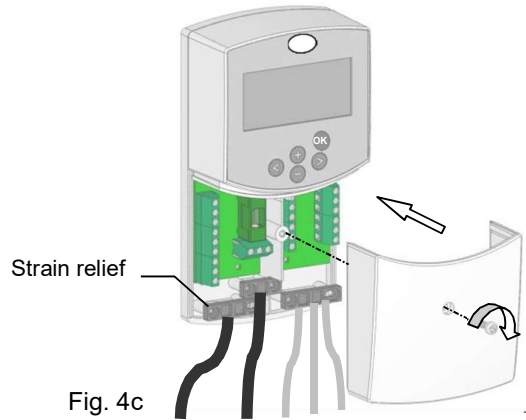

Fig. 4c

After making the electric connections, refit the front panel (fig. 4c).

5.2 Electrical connections

All electric connections must be made by an authorized specialist according to the local regulations on electric installations. The electrical cables must not come into contact with any hot components. Because of available space, we recommend that you unsheath the cables just after the cable clamp to facilitate connection:

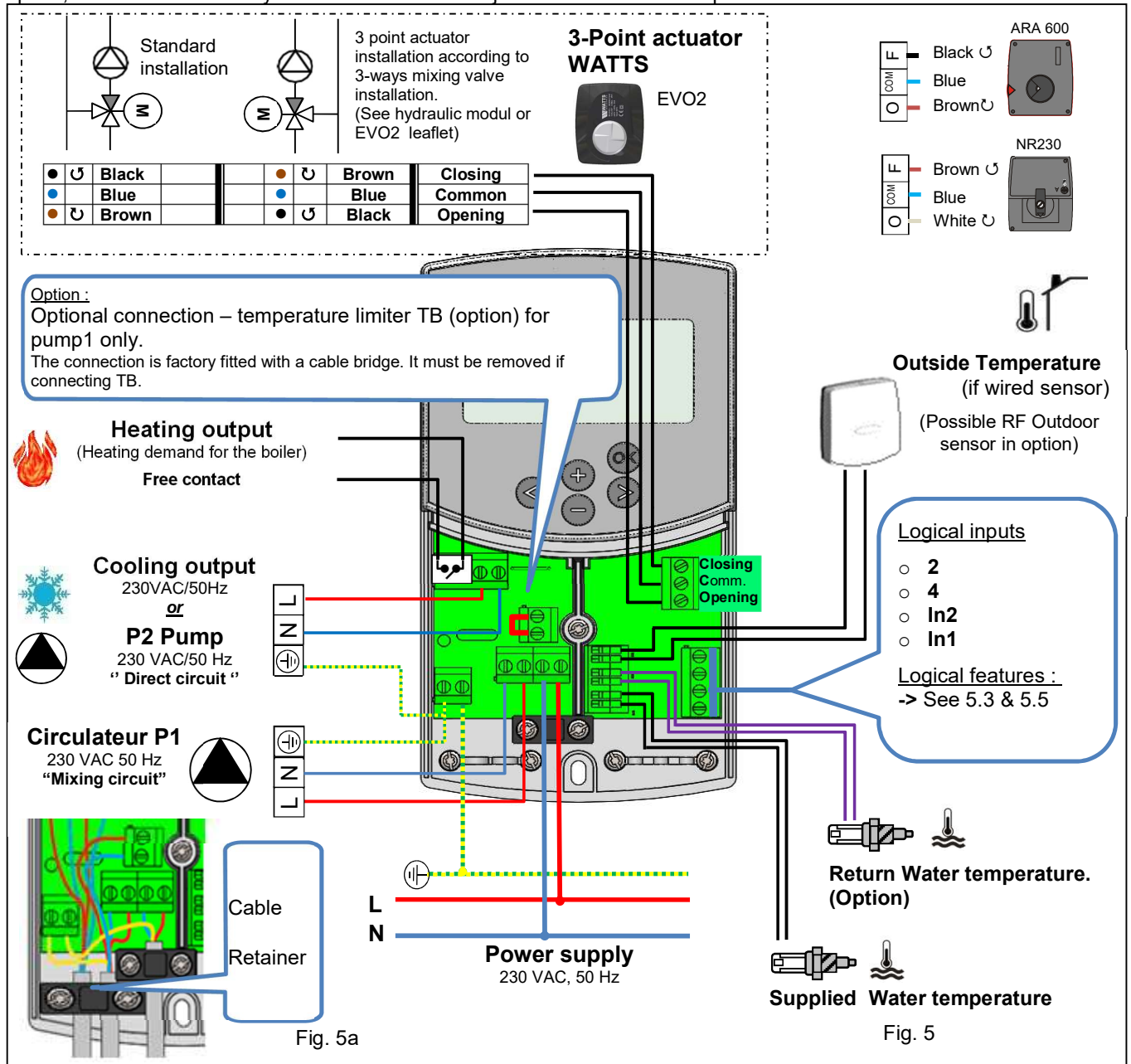

Fig. 5a

Fig. 5

5.3 Hydraulic installation

The configuration is defined by the System parameter #4: INST (See Chap 7.1 System parameters setting) and induces a different usage of the outputs:

Pump2/Cooling output :

Parameter #4 INST	Act	SEP	2P.1 or 2P.2
Output	Directive valve	Cooling demand	Pump 2

Heating output :

Parameter #4 INST	Act	SEP	2P.1 or 2P.2
Output	Heating demand or Stage 2 heating (if PE=yes)	Heating demand or Stage 2 heating (if PE=yes)	Heating or cooling demand or Stage 2 heating (if PE=yes)

Pump1 output :

Parameter #4 INST	Act	SEP	2P.1 or 2P.2
Output	Pump 1	Pump 1	Pump 1

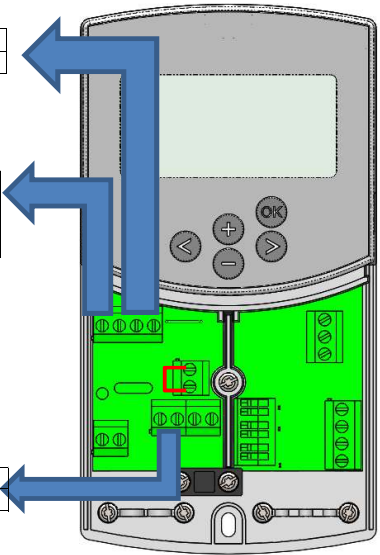

5.3.1 Single circuit hydraulic installation: Parameter #4 INST=Act

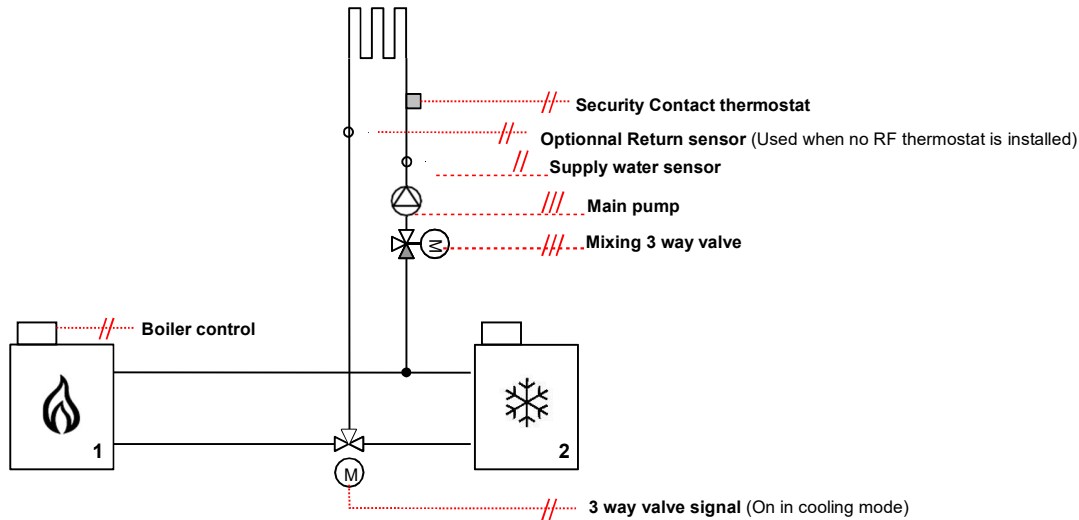

Parameter #4 INST=Act	Heating Mode	Cooling mode
Heating demand output driving the boiler or Stage 2 heating (if PE=yes)	Active (Contact closed) when the pump 1 is active or when there is a domestic hot water demand or PE=Yes with Ext Temp < PE t	Always OFF (Contact opened)
Cooling demand output (Pump 2 output) driving a 3 way On/Off valve to choose between Heating or cooling water	Always OFF (Contact opened)-> HOT	Always ON (Contact closed)->COLD
Pump 1 output with wired TH1 thermostat	Active if the thermostat is in heating demand	Active if the thermostat is in cooling demand
Pump 1 output with RF TH1 thermostat	Active if the thermostat is in heating demand	Active if the thermostat is in cooling demand

5.3.2 Single circuit hydraulic installation: Parameter #4=SEP

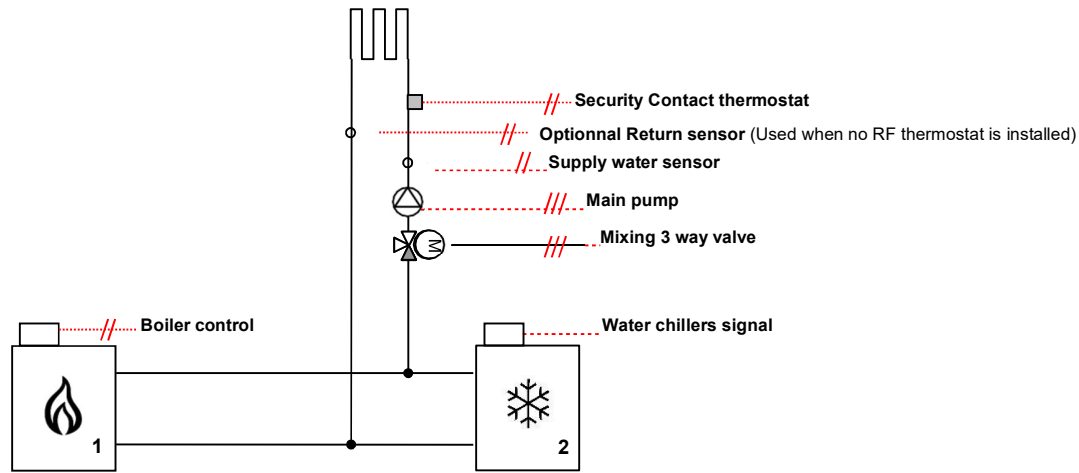

	Heating Mode	Cooling mode
Heating demand output driving the boiler or Stage 2 heating (if PE=yes)	Active (Contact closed) when the pump 1 is active or when there is a domestic hot water demand or PE=Yes with Ext Temp < PE t	Always OFF (Contact opened)
Cooling demand output driving a water chiller	Always OFF (Contact opened)	Active (Contact closed) when the pump 1 is active
Pump 1 output with wired TH1 thermostat	Active if the thermostat is in heating demand	Active if the thermostat is in cooling demand
Pump 1 output with RF TH1 thermostat	Active if the thermostat is in heating demand	Active if the thermostat is in cooling demand

5.3.3 Dual circuit hydraulic installation: Parameter #4=2P.1 or 2P.2 with wired thermostat:

(*)

2P.1 with wired thermostats: Thermostat 2 for direct circuit is a non-reversible model (Contact when ambient temperature is below setpoint). In cooling mode, the climatic control will automatically reverse the contact information.

2P.2 with wired thermostats: Thermostat 2 for direct circuit must be a reversible model (Contact when heat or cool demand).

2P.1 or 2P.2 with wired thermostat	Heating Mode	Cooling mode
Heating or cooling demand output informing the heat pump or Stage 2 heating (if PE=yes)	Active (Contact closed) when the pump 1 or pump 2 is active for heating circuits (IN1=TH1, IN2=TH2) or PE=Yes with Ext Temp < PE t	Active (Contact closed) when the pump 1 or pump 2 is active for cooling circuits (IN1=TH1, IN2=TH2) or PE=Yes with Ext Temp < PE t
Pump 2 output	Active (Contact closed) if heat demand on direct radiator circuit thermostat 2	Active (Contact closed) if cold demand on direct radiator circuit thermostat 2 (*)
Pump 1 output	Active if the wired thermostat 1 is in heating demand	Active if the wired thermostat 1 is in cooling demand

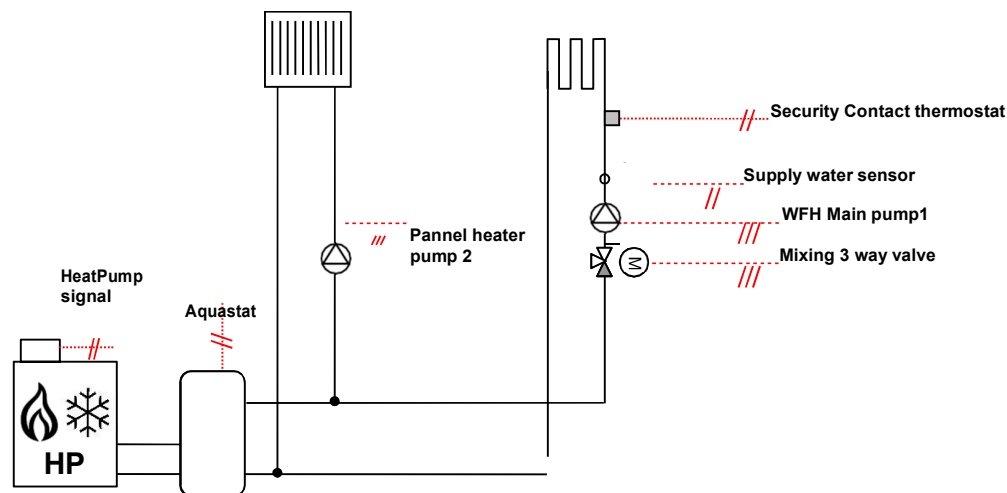

5.3.4 Dual circuit hydraulic installation: Parameter #4=2P.1 or 2P.2 with RF thermostat:

2P.1 or 2P.2 with RF thermostats have the same behavior: In cooling mode, the climatic control will automatically reverse the cooling demand if the thermostat 2 is not reversible

2P.1 or 2P.2 with RF thermostat	Heating Mode	Cooling mode
Heating or cooling demand output informing the heat pump or Stage 2 heating (if PE=yes)	Active (Contact closed) when the pump 1 or pump 2 is active for heating circuits OR when there is a domestic hot water demand through Aquastat input (IN1 or IN2) OR PE=Yes with Ext Temp < PE t	Active (Contact closed) when the pump 1 or pump 2 is active for cooling circuits OR PE=Yes with Ext Temp < PE t
Pump 2 output	Active (Contact closed) if heat demand on direct radiator circuit RF thermostat 2	Active (Contact closed) if cold demand on direct radiator circuit RF thermostat 2
Pump 1 output	Active if the RF thermostat 1 is in heating demand and Ambient temperature is lower than Setpoint +1°C	Active if the RF thermostat 1 is in cooling demand and Ambient temperature is higher than Setpoint - 1°C

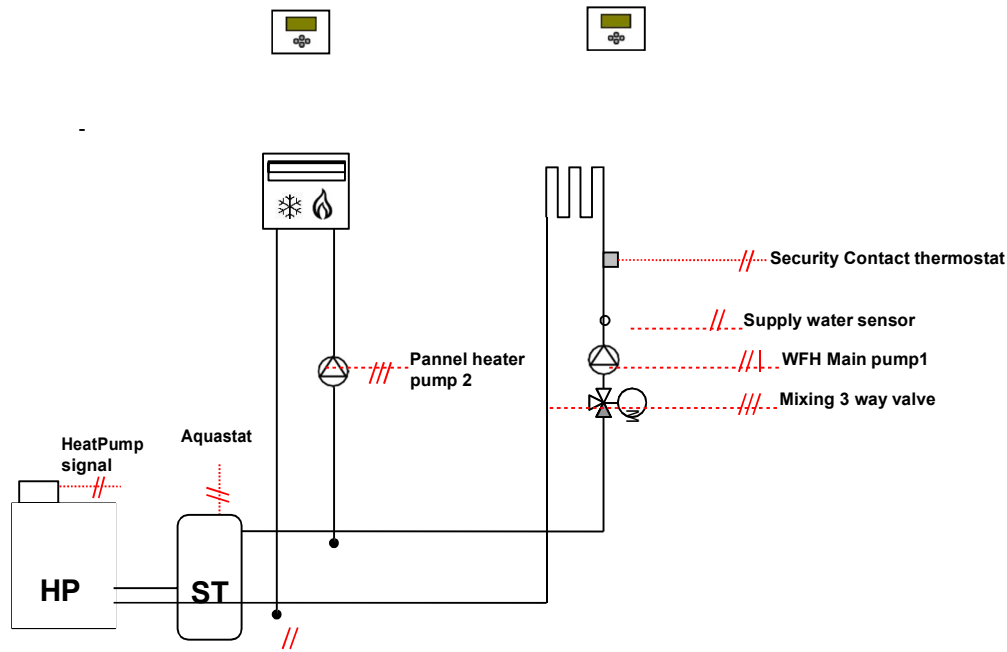

5.4 Room Temperature – Direct Plug In

As an option you can plug in a room thermostat to the ClimaticControl-HC. Direct plug in of a room thermostat optimizes the operational time of the circulation pump and even the supply flow temperature depending on the conditions in the main room.

5.4.1 Mixed circuit (Water Floor), standard room thermostat, wired type

If a wired type of a standard room thermostat is plugged in and the preset room temperature is reached in the room, the under floor circulation pump switches off after pump delay time. (PUMP: → **System parameters: pump delay time**)

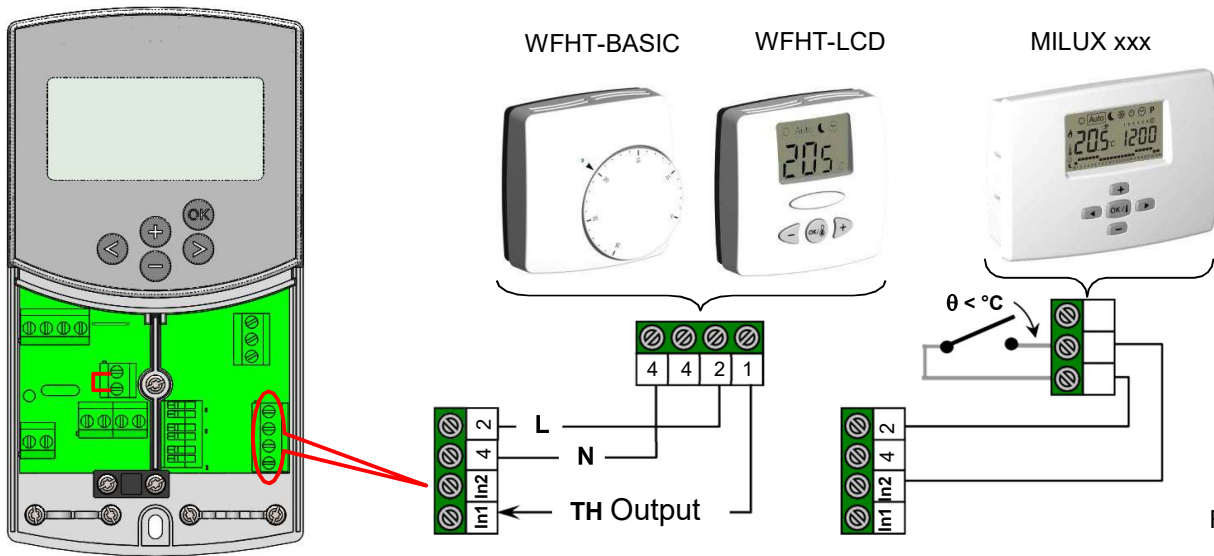

Fig. 6

5.4.2 Direct circuit (Panel Heater), standard room thermostat, wired type

If a second circulation pump is installed and managed by the ClimaticControl-HC (Inst: → **System parameters: installation type, "2P.x"**), you can install a second wired room thermostat to manage the working of the high temperature pump.

This pump will work in the following way: If the preset room temperature is reached in the room the High water temperature circulation pump switches off after pump delay time. (PUMP: → **System parameters: pump delay time**)

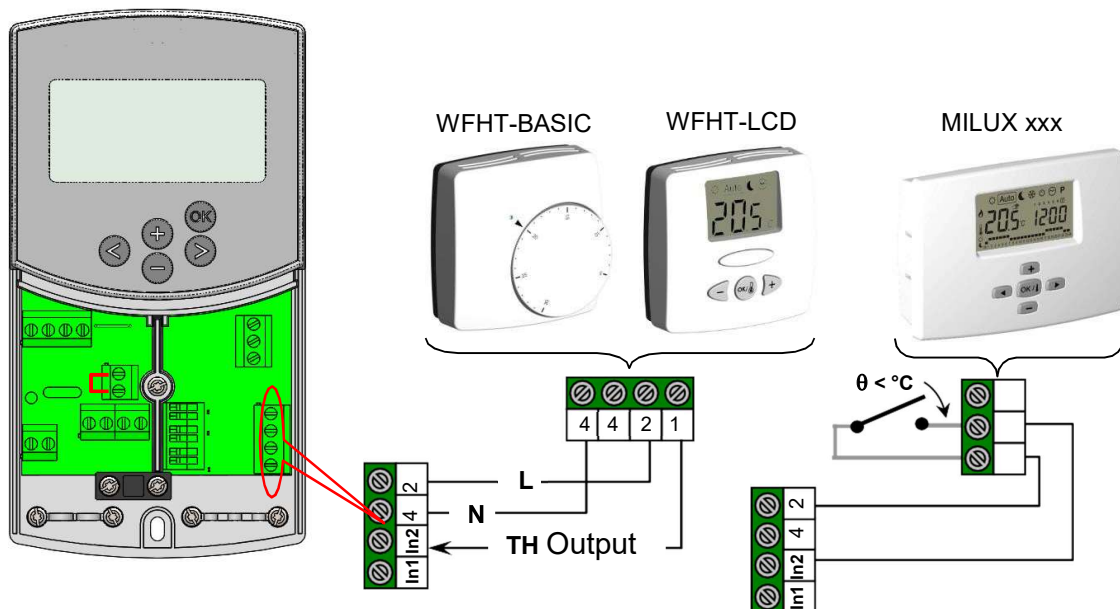
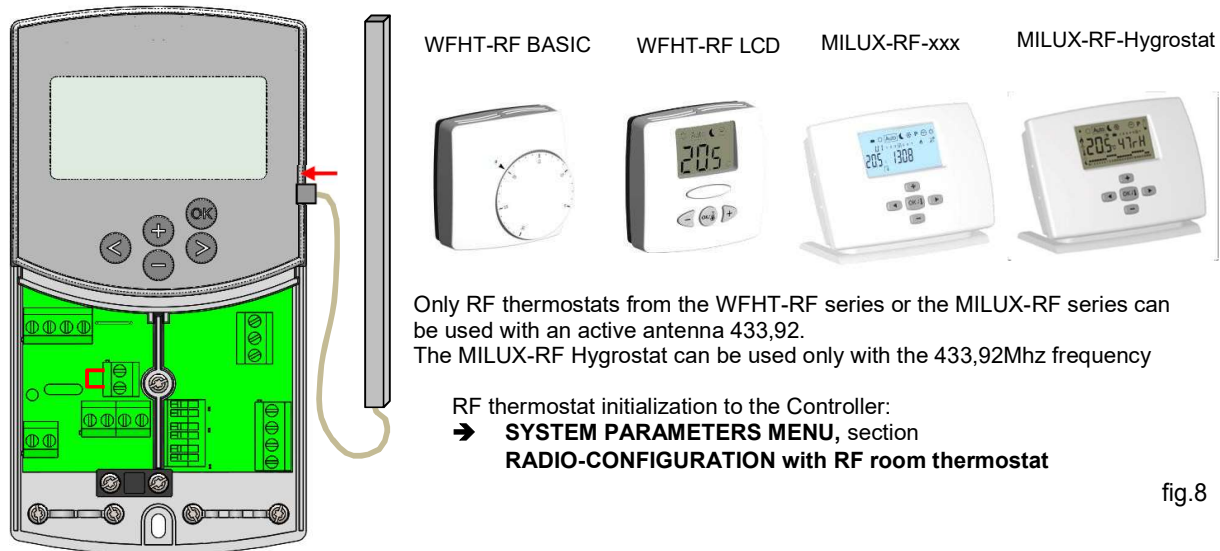

Fig. 7

5.4.3 Wireless room thermostat (Water Floor thermostat “trF1”) with WFHT-RF (BASIC, LCD or MILUX)



Only RF thermostats from the WFHT-RF series or the MILUX-RF series can be used with an active antenna 433,92.
The MILUX-RF Hygrostat can be used only with the 433,92Mhz frequency

RF thermostat initialization to the Controller:
→ **SYSTEM PARAMETERS MENU**, section
RADIO-CONFIGURATION with RF room thermostat

fig.8

If a radio frequency room thermostat is plugged in, the flow temperature calculated on the basis of outdoor temperature and the curve (= flow temperature preset value) is optimized depending on the main room temperature.

The offset value is calculated in the following way:

Adjustment = preset value of supplied temperature + (room temperature - actual value) x compensation offset

(Compensation offset: → **System parameters: “tr1o”** Flow temperature offset for “trF1”)

Example 1: preset calculated value of flow temp. = 35 °C; room temperature: preset value = 21 °C, actual value = 19 °C; offset (tr1o) = 1,5

Estimation 1: 35 °C + (21 °C – 19 °C) × 1,5K ==> flow temperature increased by 3,0K to 38 °C

Example 2: preset value of flow temperature = 35 °C; room temperature: preset value = 21 °C, actual value = 22 °C; offset (tr1o) = 1,5

Estimation 2: 35 °C + (21 °C – 22 °C) × 1,5K ==> flow temperature decreased by 1,5K to 33,5 °C

ⓘ The pump will be switched off when room temperature will be 1°C upper the setting temperature of the thermostat.

If a Milux-RF-Hygrostat is used, the program feature (See Chapter **Error! Reference source not found.**) is deported on the thermostat user interface.

5.4.4 Wireless room Hygrostat (Water Floor thermostat “trF1”)

If a radio frequency room Hygrostat is plugged in, the flow temperature calculated on the basis of outdoor temperature and the curve (= flow temperature preset value) is optimized depending on the main room temperature. (See the previous part for more explanation)

The working mode (Heating or Cooling) of the installation could be managed by the end user directly on the room hygrostat. (See the MILUX humidity leaflet for more explanation)

The residual humidity will be supervised by the MILUX-RF hygrostat in the house. If humidity is detected the “Wcal” temperature will be increased by step of 0.1°C/minute to avoid a too cold water on the hydraulic circuit and risk of condensation in the house.

5.4.5 Wireless RF room thermostat (High temperature circuit thermostat “trF2”)

If a second circulation pump is installed and managed by the ClimaticControl-HC (Inst: → **System parameters**: installation type, “2P.x”), you can install a second radio frequency room thermostat to supervise the working of the high temperature pump.

This pump will work in the following way: If the preset room temperature is reached the High water temperature circulation pump switches off after pump delay time. (PUMP: → **System parameters**: pump delay time)

ⓘ Note: Only a standard room thermostat could be installed on the second circuit.
Ex: WFHT-RF (BASIC, LCD or MILUX).

5.4.6 Wireless RF outside sensor (Inst: System parameters: Input, "OUSE").

As an option you can plug in a wireless RF outside sensor room thermostat to the ClimaticControl-HC. This solution is very interesting in rehabilitation, to avoid wires trough the wall, in a building management with several CC-HC, in this case only one outside sensor can be installed to manage all the building.

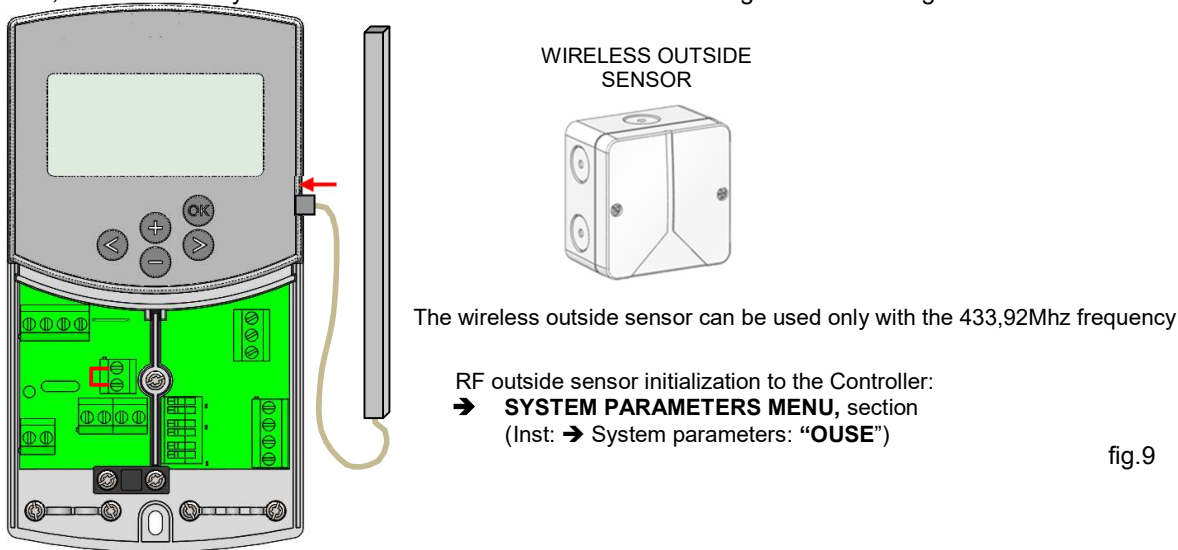

Radio alarm: RF supervising function.

If the ClimaticControl-HC is installed with RF thermostat(s) and there is no radio signal received during more than 2 hours, a display alarm will be activated, the backlight and the small RF antenna logo  radio will blink.

1. To stop the alarm, maintain the **(OK)** button pressed for about 10 seconds.
2. Check the batteries of the RF thermostat(s) or outside RF sensor. Please replace them if exhausted.
3. Check the position in which the antenna was installed. It must be installed in vertical position. Installation in or on a metal body can abate the power of radio transmission. Minimize the distance to the RF thermostat.

If radio alarm is displayed:

- Due to the wireless thermostat, the regulation will continue to work as an installation without thermostat (no compensation).
- Due to the Wireless outside sensor, the regulation will continue to work with the last value received from the outside sensor.

5.4.7 Inputs functions (In1 & In2)

If no wired thermostat is installed in the house, you will have the possibility to use the two available inputs of your ClimaticControl-HC for different functions (Inst: **-> System parameters: Input, "In1 & In2"**).

1) **Input1**

Inst: **-> System parameters: Input, "HC"**

You could use the input 1 to connect the an external signal which give the Heating or Coling working mode of the installation (This signal could be done directly by a reversible input).

Inst: **-> System parameters: Input, "Aqu"**

1/ You could use the input 1 to connect the an imersion thermostat witch schould be placed in a storage tank. In Heating mode this immersion thermostat will be use to switch off the circulation pump (Pump1) to avoid cold water circulation in the circuit if the storage tank is discharged. (This solution is generally use when solid wood burner is installed)

2/ You could also use this input to have a priority on domestic hot water.

In this case the pump of the heating circuit will be stopped to keep the priority on the domestic hot water. This configuration is not compatible with the Efficiency Point PE=Yes as the output is used to control the heating stage 2 (See parameter #15 in Chap 7.1 System parameters setting)

Note:

- The heating output will stay activated even if the aquastat have stopped the circulation pump.
- To avoid problem in cooling mode, if the storage tank is filled with cold water (by heat pump...) the aquastat function will be automatically deactivated.

Inst: → **System parameters:** Input, "C_b"

In case of mutizone regulation "WFHC Master RF with or without Heat&Cool function" is installed you could use the input 1 to connect the pump relay output to swtich off the circulation pump1 in case of no water circulation demand is asked in the house.

Note:

- The heating output will follow the circulation demand from the pump1.

2) Input2

Inst: → **System parameters:** Input, "HC"

You could use the input 2 to connect the an external signal which give the Heating or Coling working mode of the installation (This signal could be done directly by a reversible input).

! "HC" is only available if Input1 is set on "no or Aqua"

Inst: → **System parameters:** Input, "Aqu"

You could use the input 2 to connect the an immersion thermostat witch should be placed in a storage tank. In Heating mode this immersion thermostat will be use to switch off the circulation pump to avoid cold water circulation in the circuit if the storage tank is discharged.

! The immersion thermostat connected on the Input2 will manage the working of the main circulation pump (Mixed circuit) if the ClimaticControl-HC drive only one pump.

In the installation with two circulations pumps, the immersion thermostat connected on the Input2 will manage the working of the 2nd circulation pump (direct circuit).

Note:

- The heating output will stay activated even if the aquastat have stopped the circulation pump.
- To avoid problem in cooling mode, if the storage tank is filled with cold water (by heat pump...)the aquastat function will be automatically deactivated.

Inst: → **System parameters:** Input, "C_b"

In case of mutizone regulation "WFHC Master RF with Heat&Cool function" is installed you could use the input 2 to connect the pump relay output to swtich off the circulation pump in case of no circulation demand is asked in the house.

! The WFHC connecting box connected on the Input2 will manage the working of the main circulation pump (Mixed circuit) if the ClimaticControl-HC drive only one pump.

In the installation with two circulations pumps, the WFHC connecting box connected on the Input2 will manage the working of the 2nd circulation pump (direct circuit).

Example 1: Reversible installation with circulation pump (UFH application).

In1 Used to change the working mode of the installation, signal from Heat Pump (Inst: → **System parameters:** Input, "HC")

In2 used to stop the pump when D.H.W is in demand (Inst: → **System parameters:** Input, "Aqu")

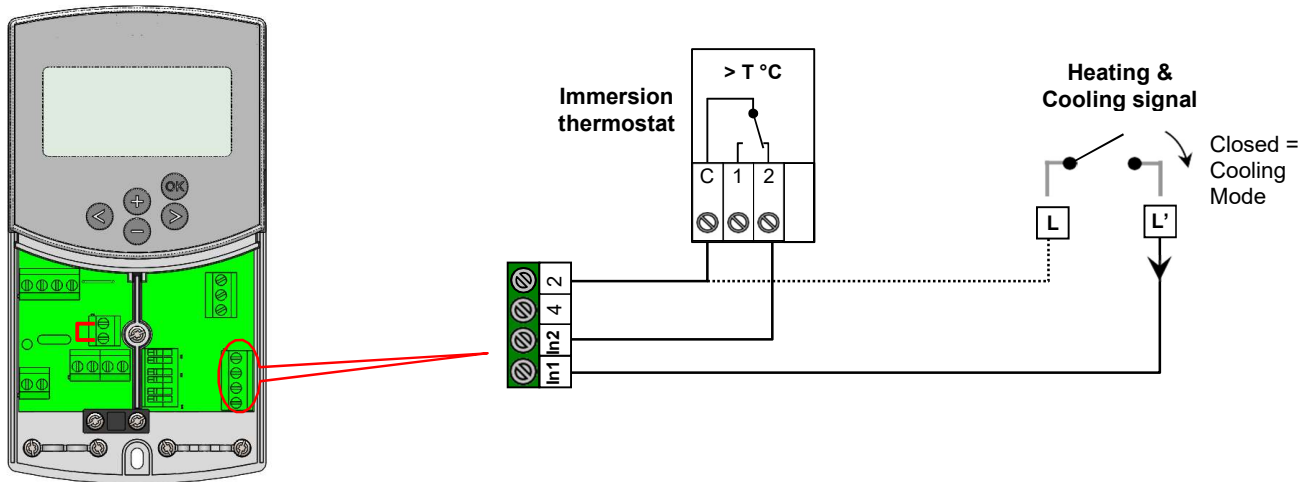

Attention:

In case of the CLIMATICCONTROL-HC must be linked with the Heat pump (from the Heat / Cool switch)

Pay attention to check the compatibility of the electrical signal before connection.

The inputs 1 or 2 (Inst: Parameter menu: In1, In2 "HC") need a live signal "Phase L" to works in cooling mode.



Fig. 10

Example 2: Under floor heating installation with multizones connecting boxes.
In1 used to stop the pump when no heat demand is asked in the house. (Inst: **Parameters menu:** In1, "C_b")
In2 used to stop the pump when the storage tank is empty (Inst: **Parameters menu:** In2, "Aqu")

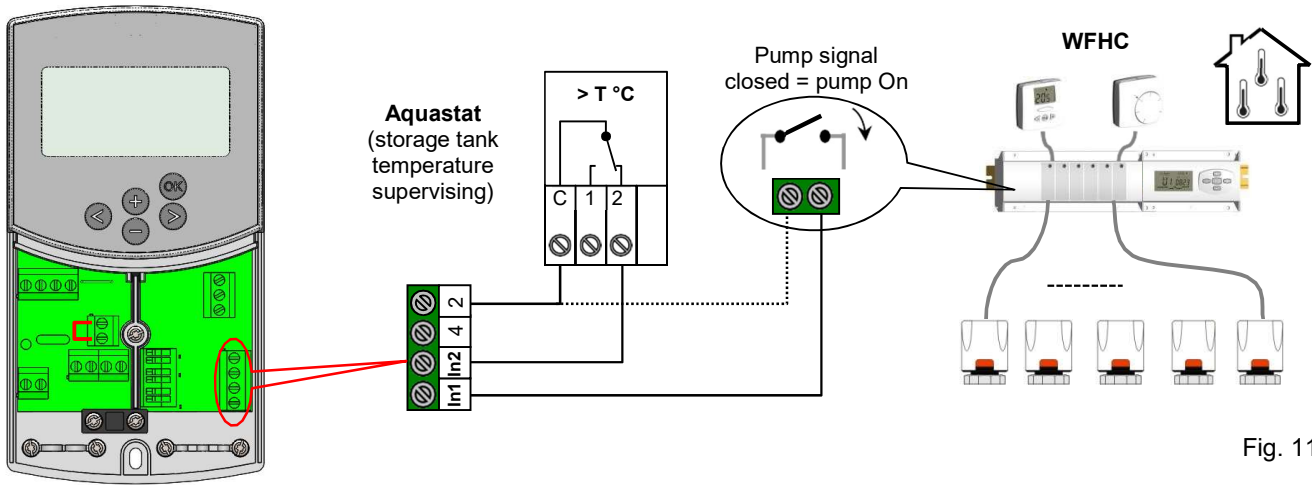

Fig. 11

Example 2: Installation with 2 circulation pumps (Under floor heating and panel heater).
In1 used to stop the pump when the heat storage is empty (Inst: → **Parameters menu:** In1, "Aqu")
In2 used to stop the pump when the heat storage is empty (Inst: → **Parameters menu:** In2, "Aqu")

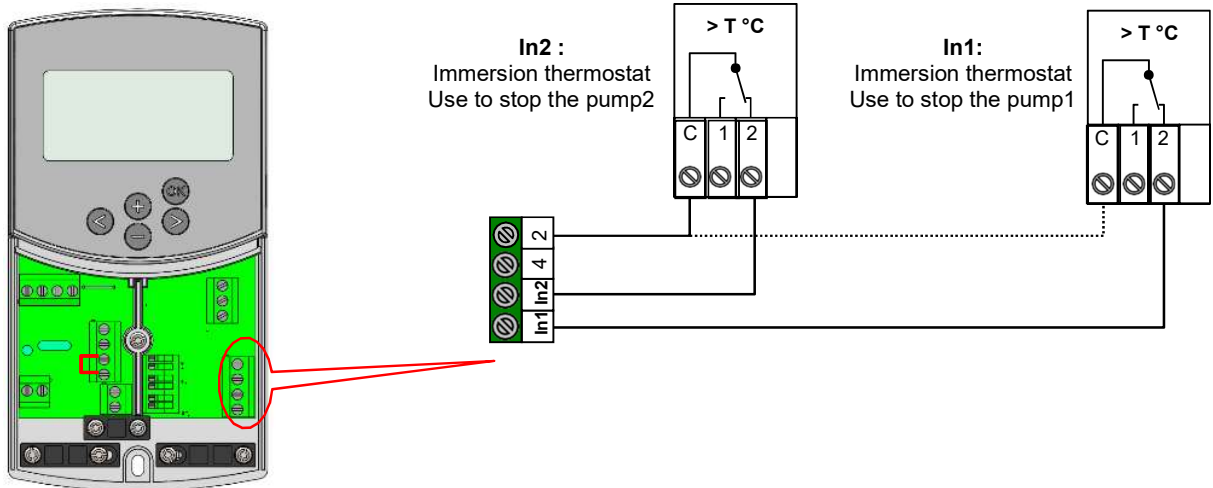

Fig. 12

6. Types of operating modes / Program menu

6.1 Heating and cooling switch

There are several ways to switch the system between heating and cooling.

- Use parameter #0 Type (See Chap 7.1)
- Use the user interface of the Climatic Control HC if parameter #0 Type=Rev (See Chap 7.1)
- Use the user interface of the paired MILUX-RF HYGROSTAT if parameter #0 Type=Rev
- Use Input 1 parameter #11 In1=HC or Input 2 parameter #12 In2 =HC (See Chap 5.4.7 and Chap 7.1)

6.2 Types of operating modes

Selection of the operating mode is done using the arrow keys (◀) and (▶). The cursor must be positioned on the symbol of the relevant operating mode.



COMFORT mode of operation

Unlimited operation in COMFORT mode ☀.

The system runs in constant comfort mode. The ClimaticControl-HC adjusts the flow temperature depending on the outdoor temperature and the selected curve. No temperature setback.

The display Pos. 5 shows the current flow temperature and the outside temperature at 13 (damped value). By pressing the button (OK) the preset value of flow temperature appears for about 3 seconds at 5. At the same time the manually selectable deviation is displayed at 13 (factory setup: 00.0 = no deviation). Using the buttons (+) or (-) you can adjust the preset value of the flow temperature. If changed, the symbol 🖱 appears on the display.

In heating mode of operation if no room thermostat is installed (MuB: ➔ 5.3), the circulation pump is running continuously. The pump switches off if the mixing 3 way valve is closed for the setting time (PUMP: ➔ **System parameters**: pump delay time). That is the case when the room heating is sufficient and the room thermostat closes all heating circuits by means of actuators. The same happens when the value of flow temperature calculated by the ClimaticControl-HC becomes lower than the actual temperature value because of rising outdoor temperatures. If the actual value of the flow temperature falls below the preset value, the pump will restart.

🔔 In this case to ensure a correct measure of the water temperature the pump will be start each 30min for a short time to measure the real temperature of water inside the hydraulic circuit.

🔔 To ensure energy saving operating mode of the pump it could be switched by a “pump logic” of a electric connecting box. The connecting box is normally used together with room thermostats and electro-thermic actuators. The “pump logic” is a potential free switching relay, the contact of which is closed whenever higher temperature is demanded in any of the rooms. If all rooms are warm enough, the contact opens and the pump turns off. (MuB: ➔ 5.5)

⚠ If the heat generator / boiler (WE) is in temperature setback and the temperature supplied by the WE is below the preset temperature calculated by the ClimaticControl-HC, heating mode is not available. However if the circulation pump is actually running and the 2/3-way valve may also be opened by the 3-point actuator because of room heating demand, the preset value of flow temperature may be exceeded for a short period of time when the WE switches to heating mode. In this case, if a temperature limiter is available, the pump might switch off and then pump operation will be possible only after the temperature drops below the preset maximum temperature of the TB.

Trouble-shooting: The TB should be installed at a greater distance from the control unit. If necessary you can set the TB to a higher temperature until the pump starts. After a few minutes of pump operation the maximum allowable temperature set on the TB should be restored. Alternatively you can remove the TB from the pipe for a while and leave the pump running for a few minutes. Then refit the TB again to the pipe.

Auto

AUTOMATIC mode of operation

Automatic mode of operation using the built-in or user programs.

The ClimaticControl-HC is controlled according to the selected built-in or user program (→ 6.2.).

The flow temperature is controlled depending on the outdoor temperature and the curve with room compensation if RF thermostat is installed. (→ 5.3.3 – 5.3.5).



→ The room compensation function will be different depending of the RF thermostat installed:

* With WFHTRF-BASIC or LCD (Non programmable thermostat)





The room temperature compensation will be taken in account only during Comfort period of the program. During the Reduced period the Water temperature will follow the curve minus the temperature setback offset.



* With MILUX RF (Programmable thermostat)

The room temperature compensation will be taken in account during Comfort  and Reduced  period of the program. In this case the program of the MILUX RF should be the same of the water program adjusted on the CC-HC to have the best optimising energy consumption (the water temperature will be reduced due to the CC-HC program (in )) and by the setting temperature reduced also in the room due to the MILUX RF program.

* With MILUX-RF HYGROSTAT (Programmable Heat and Cool thermostat with Humidity supervising)

The program will be now done on the MILUX-RF HYGROSTAT (Program made on Zone1 see the user guide of the MILUX-RF HYGROSTAT for more explanation).

The room temperature compensation will be taken in account during Comfort  and Reduced  period of the MILUX-RF HYGROSTAT program.

The Comfort and Reduced manual offsets added or subtracted to the calculated water temperature will be always adjusted on the both working mode of the CC-HC ( 0.00°C &  -10.0°C by default).

→ For the operation of the circulation pump please refer to the section of **COMFORT** mode of operation.



REDUCED TEMPERATURE mode of operation

Unlimited operation in REDUCED TEMPERATURE mode .

This is a constant mode of operation of the system. The ClimaticControl-HC adjusts the flow temperature continuously on the basis of outdoor temperature and the selected curve and subtracting the value of temperature setback (factory setting -10.0 K in Heating mode & +3.0 K in Cooling mode).

The display indicates the current flow temperature at **5** and the outside temperature at **13**. By pressing the button (**OK**) the preset value for the supply flow temperature reduced by the setback in temperature is displayed at **5** for 3 seconds. Simultaneously the reducing difference appears in **13** (without deviation = -10.0). It can be changed by the buttons (**+**) or (**-**).

→ For the operation of the circulation pump please refer to the section of **COMFORT** mode of operation.

→ See the previous part for more explanation concerning the room compensation function when RF thermostat is installed.



ABSENCE/VACATION mode of operation



Time-limited operation of REDUCED TEMPERATURE mode .

Duration can be set between 1 and 24 hours and up to a maximum of 44 days. When this period is expired the ClimaticControl-HC switches back to operating mode .

By means of the arrow keys (**←**) the cursor is first moved to  . Then  appears on the display at **13**.

The duration of absence can be changed using buttons (**+**) or (**-**).

Example: $H = 1 \text{ hour};$ $D = 1 \text{ day}$

Both symbols  and  start blinking. The remaining time is displayed at **13**.

To discontinue this mode of operation before time you have to set the remaining time at **13** to  using the (**-**) key.



STOP mode

This mode is used to switch off the system.

The device switches off the system. The ClimaticControl-HC software version is indicated on the display for about 3 seconds and then switches off (no indications).

By pressing any of the keys the ClimaticControl-HC can be switched on.

REMARK: When the ClimaticControl-HC is in **STOP mode**,

In Heating mode only an **Anti-freeze function** can restart heat relay and circulation pump to maintain the water temperature above **10°C**.



Heat & Cool Mode

Use this mode to change the working mode of your installation, Heating or cooling mode.

REMARK: This mode will be only displayed if:

- The CC-HC is configured to manage a reversible installation (Inst: → Parameters menu: Type, "Rev")
- No MILUX-RF HYGROSTAT is installed (→ 5.3.4) and configured to manage the Heat and Cool mode.
- No CC-HC inputs (In1 or In2) have chosen for a H_C signal input. (→ 5.5)

Carfull:

IF Heat pump or other system is used and not linked with the ClimaticControl-HC, pay attention to change the working mode on it before change on the ClimaticControl-HC. Because in this case the regulation will not work in the correct way.



TIME AND DATE – setting

In this menu you can set the actual time and date as well as the day of the week.

Using the cursor select first and then press the **(OK)** key.

By keys **(+)** or **(-)** set the minutes; confirm by pressing **(OK)**.

By keys **(+)** or **(-)** set the hour; confirm by pressing **(OK)**



By keys **(+)** or **(-)** set the day of the week; press **(OK)** to confirm.



(1 = Monday; 7 = Sunday)

6.3 Program Mode

REMARK: This mode will be only displayed if no MILUX-RF Hygrostat is installed (→ 5.3.4)

P PROGRAM menu

In this menu you choose the program of the Controller (duration of the periods for operation in reduced temperature and heating mode), which is to be followed in operating mode . You can choose between factory set programs from P1 to P9 (→ 6.2.1.) and one of the user's programs from U1 to U4.

First you select **P** with the help of the cursor. The indication appears at 5. Press the **(OK)** key and the indication starts blinking. By the keys **(+)** or **(-)** now you can select the program you need and confirm it by pressing **(OK)**.

User-defined Programs (U1 – U4)

If you choose one of the user programs from U1 to U4, you can program the REDUCED temperature and NORMAL heating times directly. Proceed as follows:

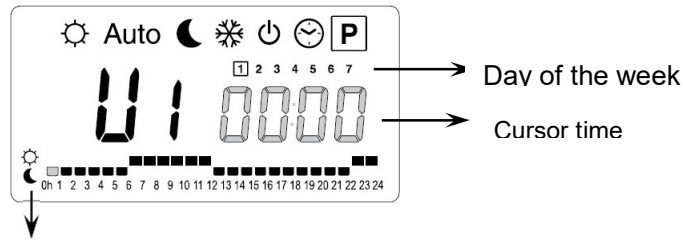

The key (+) allow you to choose a COMFORT ☀ period at the blinking cursor time. The key (-) allow you to choose a REDUCED 🌙 period at the blinking cursor time.

At 13 the time indication blinks and day 1 is highlighted, while at 7 the time cursor blinks at 0 h on the symbol ☀ (heating mode). Pressing the (-) key you can move the time cursor to the symbol 🌙 (REDUCED temperature mode). Then the time cursor jumps to the next hour. Thus COMFORT and REDUCED temperature cycles are selected using the (+) and (-) keys.

the programmed values for day 1 are stored. Programming other days is done using identical procedure moving the cursor by pressing (▶). When you switch over to programming the next day the program for the

P

previous day is saved. On completing the programming of the last day 7, the indication first switches to the program menu **P**, and in about 15 seconds back to Auto.

If during programming no inputs are made within 20 seconds, indication switches first to the program menu **P**, and in another 15 seconds it returns to Auto. The inputs were not stored.

Factory / built-in programs (P1 – P9)

If you select any of the factory programs from P1 to P9, you confirm it by pressing the key (OK). Then pressing the arrow key (◀) scroll back to the menu for selecting an operation mode (if the arrow key is not pressed in about 15 seconds the display turns back to operating mode Auto).

6.3 Factory set COMFORT & REDUCED temperature times in programs P1 - P9

P1: Morning, Evening & Week-end

P2: Morning, Midday, Evening & Week-end

P3: Day & Week-end

P4: Evening & Week-end

P5: Morning, Evening (bathroom)

P6: Morning, Afternoon & Week-end

P7: 7h - 19h (Office)

P8: 8h – 19h , Saturday (Shop)

P9: Week-end (Secondary House)

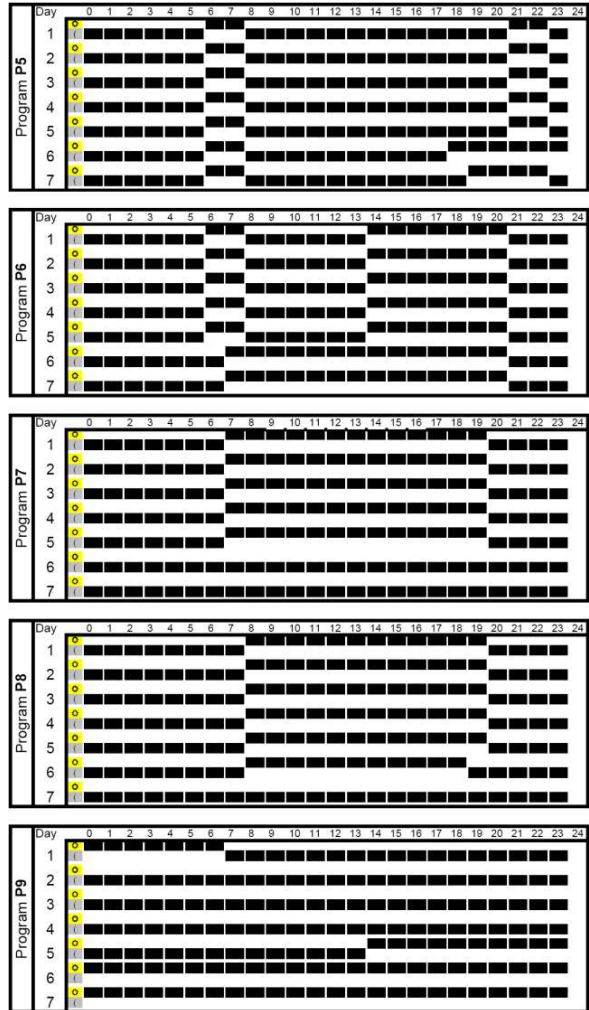
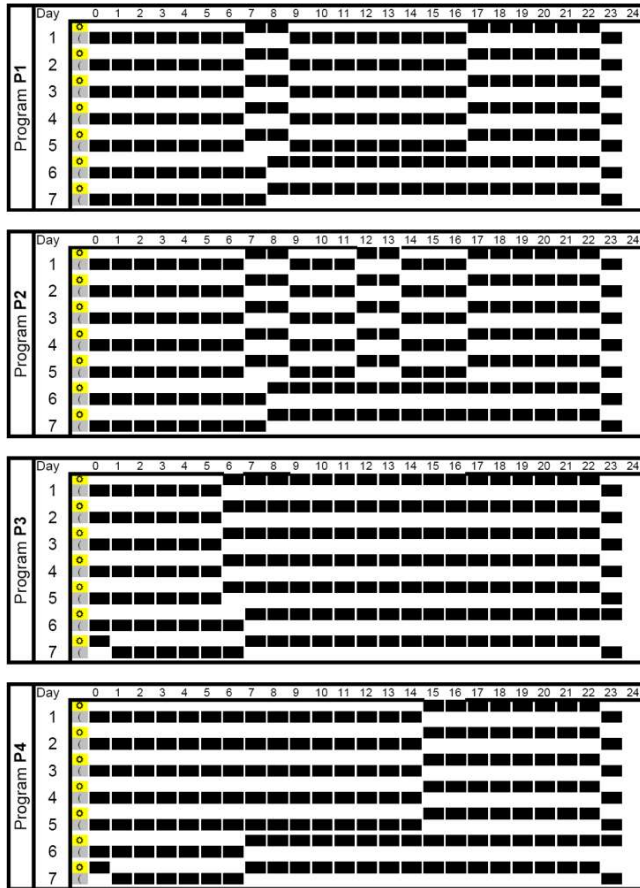

⚠ The ClimaticControl-HC program operates only in REDUCED temperature periods.

Auto mode according to the selected COMFORT and

7 System Parameter Menu

7.1 System parameters setting

This menu is used to set the most important parameters for the operation of the system.

To access this menu keep the **(OK)** key pressed for 10 seconds (in Comfort, Auto, Reduced modes).

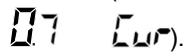
The display shows  as well as the preset curve (for example ).

Parameters are selected by pressing the **(◀)** or **(▶)** keys.

To change the parameters press **(OK)** and using **(+)** or **(-)** change them. To leave the menu goes to the parameter **“End”** and press the **(OK)** key.

SYSTEM PARAMETERS				
Values	Parameters description	Factory setting	Alternative setting	 setting
0 --- Type	Type of installation Following your choice, the list of parameter will be different. Ex: The Cooling "curve" parameter will be not displayed if you choose "Hot" installation.	Hot	CLd, rEv	
	Hot For Heating installation only			
	CLd For Cooling installation only			
	rEv For reversible installation			
Heating parameters				
* 0.7 °C _{ur} 1	Heating curve value (see fig. 7) supplied water T° = curve(outside T°)	0.7	0.1 to 5	
* 45.0 °C _{Hi} 2	Maximum value of flow temperature in Heating mode	45 °C	(Lo+5°C) – 100 °C	
* 10.0 °C _{Lo} 3	Minimum value of flow temperature in Heating mode	10 °C	1 – (Hi-1°C)	
Remark: The thermostat has the priority over the water law limits on the pump and heating outputs. Thus the 3-way valve will always follow the limits set above.				
Cooling parameters				
* 0.4 *C _{ur} 1	Cooling curve value (see fig. 7) supplied water T° = curve(outside T°)	0.4	0.1 to 5	
* 30.0 °C *C _{Hi} 2	Maximum value of flow temperature in Cooling mode	30 °C	(Lo+5°C) – 100 °C	
* 15.0 °C *C _{Lo} 3	Minimum value of flow temperature in Cooling mode	15 °C	1 – (Hi-1°C)	
Remark: The thermostat has the priority over the water law limits on the pump and cooling outputs. Thus the 3-way valve will always follow the limits set above.				
4 --- Inst	Configuration of the hydraulic installation	SEP	Act,	See hydraulic example section
	Act: installation with actuators The "Cold output" will manage a 3 way On/Off valve to choose Heating or cooling input. The "Heat output" will manage the Boiler.			
	SEP: Installation with separate system (Boiler and chillers) One output for each element will be available.			
The two following parameters are specially made for WATTMIX regulation or all others applications with 2 pumps circuits, The second pump will follow the 2nd wired thermostat, and will be wired on the "Cold output".				



	<p>2P.1: Panel Heaters + water floor heating and cooling system</p> <p>2P.2: Fan coil units and Water Floor Heating and Cooling system</p>		<p>2P.1 The second pump for direct temperature circuit (panel heater) will be stopped in cooling mode. No cold water in panel heater!</p> <p>2P.2 The second pump is used to control a fan coil circuit.</p>	
5 --- th	<p>Thermostat selection menu:</p> <p>No: Installation without thermostat Yes: Wired thermostat(s) is installed. rF: Wireless RF thermostat(s) is installed.</p>	No	No, Yes, rF	
The following parameter is only available if "th" parameter is set to "Yes"				
6 --- thty	<p>Wired thermostat type selection:</p> <p>Std: Standard Heat only thermostat rEv: Reversible Heat&Cool thermostat</p>	Std	Std, rEv	
SYSTEM PARAMETERS				
Value	Parameters description	Factory setting	Alternative setting	 setting
The following parameter is only available "th" parameter is set to "Yes" or "no" and if water sensor is mounted on the return pipe of the hydraulic circuit.				
7 --- bGAP	<p>bGAP Boost function</p> <p>The incoming water temperature will be increased by +20%* if the return temperature is less than calculated water temperature minus bGAP setting. Wret < Wcal – bGAP => WCal +20%*</p> <p>Press on the (OK) to view the instantaneous value of the return sensor.</p> <p><u>Remark:</u> if no water return sensor is wired then this boost function is bypassed. <u>*Remark2:</u> in Cold mode Wret > Wcal + bGAP => WCal +20%</p>	10.0°C	1 to 20°C	
The following parameter is only available if "th" parameter is set to "rF"				
8 --- trF1	<p>RADIO-CONFIGURATION with RF thermostat for room temperature (trF1)</p> <ol style="list-style-type: none"> 1. Press the (OK) key. Using the (+) or (-) keys to set the Controller into rf init mode. „INI thrF“ appears on the display. 2. Set the RF thermostat into rf init mode (→ MuB). 3. If successful rf initialisation the RF thermostat sends a radio signal to the Controller. The actual value of room temperature appears flashing on the display instead of "INI". 4. The process is completed by pressing the (OK) key of the Controller. 5. Exit the rf init mode of the RF thermostat. (→ MuB). 			

	<p>Selecting „no thrF“ disconnects the RF thermostat from the Controller and discontinues the room temperature plug-in function respectively. Connection of wireless room thermostat is only possible using appropriate device.</p>		
<p>The following parameter is only available if “th” parameter is set to “rF” and if “inst” parameter is set to “2P.1” or “2P.2” (2 pumps mode)</p>			
9 --	tRF2	<p>RADIO-CONFIGURATION with RF thermostat for WATTMIX system (trF2) (2 pumps system with panel heaters or fan coils)</p> <p>same radio configuration sequence as parameter “trF1” just above</p>	
<p>The following parameter is only available if “th” parameter is set to “rF”</p>			
10 --	tR1o	<p>Flow temperature offset for RF thermostat for room temperature (trF1)</p> <p>See the working explanation (→ 5.3.3).</p>	
<p>SYSTEM PARAMETERS</p>			
11 --	in1	<p>Wired Input1 selection: (→ 5.5.1).</p> <p>th1: the wired room thermostat should be wired on Input1 because “th” parameter is set to “YES”)</p> <p>no: Input1 not used (nothing wired)</p> <p>Aqu: A water Aquastat contact is wired on Input1. If over temperature is reached (contact open) then Pump1 circulator is stopped and the mixing valve is closed.</p> <p>HC: A Heat/Cool switching signal is wired on Input1 to manage the working mode of the installation. (contact between point 2 and In1 or phase signal on In1) Heating = no signal (open circuit) Cooling = Phase signal (closed circuit)</p> <p>C_b: A pump signal from a connecting box is wired on Input1 to manage the working of the pump1. (contact between point 2 and In1 or phase signal on In1) Pump ON = Phase signal (closed circuit) Pump OFF = no signal (open circuit)</p>	<p>th1 un-adjustable</p> <p>no, Aqu, HC or C_b</p> <p>no</p>
12 --	in2	<p>Wired Input2 selection: (→ 5.5.2).</p> <p>th2: the wired thermostat for second pump system should be wired on Input2 (because “th” parameter is set to “YES” and “inst” is set to “2P.x”)</p> <p>no: Input2 not used (nothing wired)</p>	<p>th2 not-adjustable</p> <p>no, Aqu, HC or C_b</p> <p>no</p>







The HC signal could be done by a heat pump. Check the electrical compatibility before connection

	<p>Aqu: A water Aquastat is wired on Input2. If over temperature is reached (contact open) then: - if "inst"="Act or SEP", Pump1 circulation is stopped & mixing valve is closed. - if "inst"="2P.x", direct circuit Pump2 circulation is stopped</p> <p>HC: A Heat/Cool switching signal is wired on Input1 to manage the working mode of the installation. (contact between point 2 and In1 or phase signal on In1) Heating = no signal (open circuit) Cooling = Phase signal (closed circuit).</p>		 <p>The HC signal could be done by a heat pump.</p> <p>Check the electrical compatibility before connection</p>	
	<p>C_b: A pump signal from a connecting box is wired on Input1 to manage the working of the pump1. (contact between point 2 and In1 or phase signal on In1) Heating = no signal (open circuit) Cooling = Phase signal (closed circuit).</p> <p>- if "inst"="Act or SEP", water floor Pump1 circulation is stopped & mixing valve is closed. - if "inst"="2P.x", direct circuit Pump2 circulation is stopped.</p>			
13 --	<p>OUSE</p> <p>Outside sensor menu: Yes: Wired outside sensor is installed.</p> <p>No: Installation without outside sensor The regulation will work like a "thermostat" with a adjustable "Wcal" temperature injected on the circuit.</p> <p>rF: Wireless RF outside sensor is installed.</p>	Yes	No, rF	
The following parameter is only available if no outside sensor is installed and the "OUSE" parameter is set to "no".				
14 --	<p>OU t</p> <p>Outside temperature: This menu is used to fix the outside temperature to have the desired calculated water temperature in accordance to the curves.</p> <p>Example: Ou t = 0°C, Curv = 1 Wcal => 40°C</p> <p>You could adjust with more accuracy the "Wcal" temperature since the main screen with the "Comfort" and "Reduced" offset.</p>	00.0°C	-49.0°C to 50.0°C	
The following parameter is only available if "OUSE" parameter is set to "rF"				
14	<p>no ourf</p> <p>RADIO-CONFIGURATION with RF sensor for outdoor temperature</p> <p>Same radio configuration sequence as parameter 8 "trF1" above.</p>			
15	<p>PE (Efficiency Point)</p> <p>For an installation requiring additional external heat (e.g. electrical back-up, boiler, heat pump). This function can be activated in order to control a backup stage 2 heat generator using the free contact (5A 220V AC) "Heating output".</p>	No	Yes	

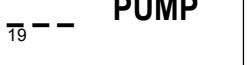
	If PE = No → Conventional operation of the free contact "Heating output" (See Chap 5.3) If PE = Yes → See below explanations on "PE t"			
PE t (Efficiency Point temperature setpoint) 15	Setting the desired PE outdoor temperature. If PE = Yes • If the outdoor temperature is lower than the Efficiency Point temperature setpoint and if a heating request occurs, then the free contact of the "heating output" will be closed to control an auxiliary heat generator. • If the outdoor temperature is higher than the Efficiency Point temperature setpoint, and if a heating request occurs, then the free contact of the "heating output" will remain opened, forbidding to switch on a backup heat generator.	-7°C	-20°C to + 15.0°C	
 16	Temperature indication in °C or °F	°C	°F	
 17	Time indication mode 24 hours or 12 hours	24H	12H Am/Pm	
 18	Side-track protection	YES (active)	NO (inactive)	
	When YES is selected the pump and the auxiliary actuator are activated at midday 12 hrs, if they haven't been active for a period of 24 hours. (12h00: Pump ON 1min, 12h01: Open actuator 2min, 12:03: Close actuator 2min)			

The following parameter "**Pump**" is only used when no RF thermostats are installed and if no inputs (In1 & In2) are used for connecting box (C_b) and aquastat (Aqu) function.

 19	Pump delay time: Time duration to switch off the pump after the stop demand from the wired thermostat or after complete close of the 3 way mixing valve. This function is also interesting to avoid permanent ON/OFF cycle of the pump when "PWM" thermostat is installed.	030 For best use the duration should be => 2xPWM cycle of the thermostat	001 to 060, and above " - - - " = infinite delay, the pump will be ON all the time
 20	Manual mode (or test function) for valve drive respectively 2/3-way valve By pressing the (+) key the valve drive opens. The display shows "OPEN" and ▲. By pressing the (-) key the valve drive closes. The display shows "CLOSE" and ▼. By pressing the (◀) or (▶) key current position of the valve drive is kept. Displays "STOP" ⚠ There is a actuator security anti-short delay: when switching from "OPEN" to "CLOSE" or "CLOSE" to "OPEN", the actuator will be stopped during 15s		
 21	Floor / screed preheating program.	0 PrH 7 PrH	
	The program is started by selecting „7 dry“ and runs automatically. For a period of 3 days the flow temperature is kept at 25 °C (days 7, 6, 5). For next 4 days the flow temperature is maintained at its preset maximum value (days 4, 3, 2, 1). The number of the days until the end of the heating program is displayed.		
 22	Floor / screed dehumidification program	0 drY 7 to 60 days Default value after "ON" => 13 Days	
	The program is started by selecting the desired numbers of days and runs automatically. Example: 13 days selected: (3days rise + 7days at Hi + 3days decrease) For a period of 3 days the flow temperature will be increased up to the "Hi" value, then the temperature will be kept at the "Hi" value during 7 days. For the last 3 days the temperature will be decreased up to the "Lo" value. Example2: 7 days selected: (3days rise + 1day at Hi + 3days decrease) The number of the days left until the end of the floor dehumidification program is displayed.		

<div style="font-size: 2em; font-family: monospace;">Clr ALL</div> <div style="font-size: 1.5em; font-weight: bold; margin-top: 10px;">End</div>	<p>Reset function By keeping the (OK) key pressed for about 5 seconds all system parameters, time and day of the week as well as user programs in are reset to the factory setting. Established radio configuration to rf thermostats, if any, is also erased. The cursor moves to . Press on the (OK) key to exit the installer menu and come back to the main menu in mode.</p>
--	--

7.2 Heating & Cooling curves

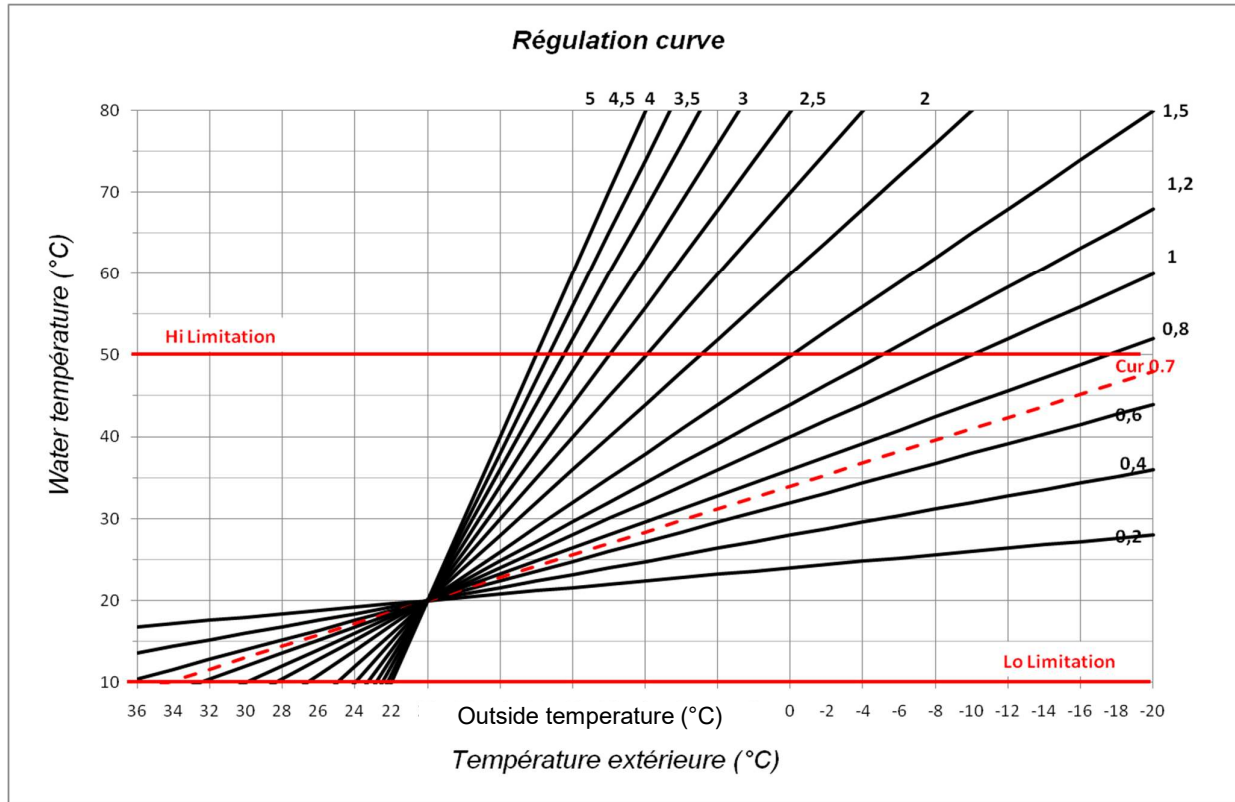

Fig. 9

7.3 Corresponding value for sensors.

To be checked with an ohmmeter with sensor unplugged.

Temperature (°C)	Resistance value (Ohm)	Temperature (°C)	Resistance value (Ohm)
-20°C	~94 kΩ	40°C	~5,3 kΩ
-10°C	~54 kΩ	50°C	~3,6 kΩ
0°C	~32 kΩ	60°C	~2,5 kΩ
10°C	~20 kΩ	70°C	~1,8 kΩ
20°C	~12,5 kΩ	80°C	~1,3 kΩ
30°C	~8 kΩ		

8. Technical Data / Materials

Measured temperature accuracy:	0,1 °C
Operating temperature:	0 - 50 °C
Flow temperature control range:	0 - 100 °C
Regulation characteristics:	Non-linear logarithmic PID control Intelligent 3-point control (automatic detection of operating point)
Electrical protection:	Class II – IP 30
Supply voltage:	230 V (±10%), 50 Hz



Outputs:

 : 5 A / 250 V relay (L, N, PE)

 : 5 A / 250 V relay (L, N, PE)

 : 5 A / 250 V relay (Free contact)

 : 2 TRIACS => 75 W max.

"Maximum opening time 240 seconds; Suitable for actuators that have an opening time below 240 Seconds"

Sensors: : CTN 10 KΩ at 25 °C (class II, IP55)

 : CTN 10 KΩ at 25 °C (class I, IP68, no coupling)

 : CTN 10 KΩ at 25 °C (class I, IP68, no supply)

Software version: (displayed when switched off – **STOP** mode).

9. TROUBLE-SHOOTING

X.	TROUBLE	
X.X	Possible reason	Elimination
1.	The display shows $\bar{E}rr$	
1.1	$\bar{E}rr$ at 13 Disconnected outside temperature sensor	Check whether the connection of sensor cable is correct. Check the cable for damages. Replace the cable or the sensor, if necessary.
1.2	$\bar{E}rr$ at 5 Disconnected flow temperature sensor	Check whether the connection of sensor cable is correct. Check the cable for damages. Replace the cable or the sensor, if necessary..
2.	Incorrect flow temperature	
2.1	Incorrect flow setting temperature The displayed calculated temperature is not in accordance with the regulation curve.	Check if no offset are adjusted (→ 6.1). COMFORT and REDUCED temperature Offset.
2.2	Too high flow temperature due to incorrectly connected valve drive (reverse action)	Check the connection of the valve drive (→ 5.2).
2.3	Too low flow temperature due to incorrectly connected valve drive (reverse action)	Check the connection of the valve drive (→ 5.2).
2.4	Incorrect selected operation mode	Select the correct mode of operation.
2.5	When ClimaticControl-HC operating in AUTOMATIC mode: - incorrect programming of built-in or user program - incorrect setting of time / day of the week	- Check the factory program or the user program settings and pay attention to the correct setting of COMFORT and REDUCED temperature periods of operation. - Check the setting of the time / day of the week.
3.	The pumps or the valve drive does not work	
3.1	Cable connections reversed.	Check the electric connections (→ 5.2).
3.2	Pump connected to temperature limiter.	- Check the electric connection (→ 5.2). - Check the maximum temperature setting of the TB. - Check the ambient temperature of the TB. If necessary, change its position. - Check the TB operation. Replace it if necessary.



Remark:  **Lock function**

To prevent mistakes after installation, all critical parameters are not accessible any more after 4 hours power on. If you want to modify these parameters, you must unplug and plug in controller. No settings are lost when unplugging, or after a power failure.
After 4 hours you can still change all the other parameters to optimize your system.

United Kingdom

Watts Industries UK Ltd
Colmworth Business Park
Eaton Socon
St. Neots
PE19 8YX United Kingdom
T: +44 (0) 1480 407074
F: +44 (0) 1480 407076
Email: wattsuk@wattswater.com
<http://wattswater.co.uk>

Germany, Austria and Switzerland

Watts Industries Deutschland GmbH
Godramsteiner Hauptstr. 167
76829 Landau
Germany
T: +49 (0) 6341 9656 0
F: +49 (0) 6341 9656 560
Email: wide@wattswater.com
<http://wattswater.de>

France

Watts industries France
1590 avenue d'Orange CS 10101 SORGUES
84275 VEDENE cedex - (France)
T: +33 4 90 33 28 28
F: +33 4 90 33 28 29/39
E-mail: contact@wattswater.com
<http://wattswater.fr>

Belgium

Watts Benelux
Beernemsteenweg 77A
8750 Wingene
Belgium
T: +32 51658708
F: +32 51658720
Email: benelux@wattswater.com
<http://wattswater.eu>

Netherlands

Watts Water Technologies Benelux
Kollergang 14
6961 LZ Eerbeek Netherlands
Tel: +31 313673700
Email: benelux@wattswater.com
<http://wattswater.eu>

Italy

Watts Industries Italia S.r.l.
Via Brenno, 21
20853 Biassono (MB)
T: +39 039 4986.1
F: +39 039 4986.222
Email: info@wattsindustries.it
<http://wattswater.it>

Spain

Watts Ind. Ibérica, S.A.
Pol. Ind. La Llana - Av. La Llana, 85
08191 Rubí (Barcelona) Spain
T: +34 902 431 074
F: +34 902 431 075
E-mail info@wattsiberica.es
<http://wattswater.eu>

Denmark, Sweden, Norway and Finland

Watts Industries Nordic AB
Godthåbsvej 83
DK-8660 Skanderborg
T: +45 86520032
F: +45 86520034
E-mail: wattsnordic@wattswater.com
<http://wattswater.eu>

Bulgaria

Watts Industries Bulgaria
Industrial zone Trakia
33, Nedyalka Shileva Str
P.O. Box 55 (post-office Trakia)
4023 Plovdiv, Bulgaria
T: +359 32 605 300
F: +359 32 605 301
E-mail: info@wattsindustries.bg
<http://wattswater.eu>

Poland

Watts Industries Polska sp.z o.o.
Puławska 40A
05-500 Piaseczno
T: + 48 22 702 68 60
F: + 48 22 702 68 61
Email: biuro@wattswater.com
<http://wattswater.pl>

Russia

Контакты
<http://wattsindustries.ru/contacts/>
<http://wattsindustries.ru>

The descriptions and photographs contained in this product specification sheet are supplied by way of information only and are not binding. Watts Industries reserves the right to carry out any technical and design improvements to its products without prior notice. Warranty: All sales and contracts for sale are expressly conditioned on the buyer's assent to Watts terms and conditions found on its website at www.wattswater.eu Watts hereby objects to any term, different from or additional to Watts terms, contained in any buyer communication in any form, unless agreed to in a writing signed by an officer of Watts

