

Series HKFC25

Pump mixing valve group with
electrical fix point control for heating systems

Installation and Operating Manual

(translated from the original operating manual)



Contents

1	General information	2
1.1	Important information.....	2
1.2	Product conformity.....	2
1.3	Product features.....	2
2	Safety	3
2.1	Presentation of the safety instructions.....	3
2.2	Important safety instructions.....	3
2.3	Intended use	3
2.4	Foreseeable misuse	3
2.5	Responsibilities of the operator	3
2.6	Groups of persons	3
3	Technical data.....	4
4	Pressure loss curve	5
5	Overall dimensions.....	5
6	Components overview	6
7	Installation and commissioning	6
7.1	Installation diagram	7
7.2	Installation	7
7.3	Initial commissioning	7
7.4	Thermometer handle position	7
7.5	Exchanging the supply and return line	8
8	Maintenance	9
8.1	Annual maintenance intervals.....	9
8.2	Replacement of wear parts.....	9
8.3	Disassembling the circulation pump.....	10
8.4	Installation of the circulation pump.....	10
8.5	Disassembling the 3-way mixer.....	11
8.6	Installing the 3-way mixer.....	11
8.7	3-way mixer motor setting.....	11
9	Disposal.....	12
9.1	Return shipment to the manufacturer.....	12
9.2	Reporting to administrative bodies and manufacturer..	12
10	Guarantee.....	12

1 General information

1.1 Important information

NOTICE The operator is responsible for ensuring adherence to the local laws and regulations (e.g. accident prevention regulations, etc.).

Incorrect operation or operating the pump group contrary to the specifications shall void all rights to any warranty claim.

This Installation and Operating Manual

- is a component of the pump group
- contains instructions and information on safe and correct installation and commissioning of the pump group
- must be available to all users throughout the entire service life of the pump group
- is intended for trained personnel who are familiar with the applicable standards and provisions and, in particular, with the relevant safety concepts and the operation and maintenance of the pump group
- is protected by copyright and may not be changed without the manufacturer's permission
- may not be made accessible to non-authorized personnel; neither in original form nor as a copy

1.2 Product conformity

A Declaration of Conformity according to the Machinery Directive 2006/42/EC has been issued for this pump group product.

1.3 Product features

- stable mounting bracket including mounting hardware
- patented 3-piece EPP insulating shell
- compact, space-saving design

2 Safety

2.1 Presentation of the safety instructions

⚠ DANGER DANGER indicates an imminent danger that may cause serious physical injury or death without the corresponding safety precautions.

⚠ WARNING WARNING indicates a danger arising through incorrect behavior that may cause serious physical injury or death (e.g. misuse, disregarding notices, etc.).

⚠ CAUTION CAUTION indicates a potentially dangerous situation that may cause minor or slight injuries without the corresponding safety precautions.

NOTICE NOTICE indicates a situation that may cause material damage without the corresponding precautions.

2.2 Important safety instructions

- Carefully read through these operating instructions.
- Only connect the pump group to a power source that corresponds to the mains voltage specified on the rating plate of the pump group.
- The power supply to the pump group must be disconnected prior to maintenance, cleaning and repair work.
- Only trained specialist personnel are permitted to perform maintenance, cleaning and repair work.
- The pump group must not be used if it is damaged or if the pump group is no longer operating correctly. In this case, contact your specialist dealer immediately.
- Adhere to the maintenance instructions and intervals.
- Protect the pump group from the influences of weather.
- Never use the pump assembly outdoors.
- The machine is only permitted to be used for the purpose for which it was intended.

2.3 Intended use

The pump group is used to distribute heating water in heating systems.

The pump group is completely pre-assembled and designed for mounting on a wall.

The pump group is not intended to be operated by people (including children) with physical, sensory or mental disabilities, nor by people with insufficient experience or previous knowledge.

2.4 Foreseeable misuse

The following is considered to be foreseeable misuse:

- operating the pump group contrary to the specifications
- improper use of the pump group
- modifications to the pump group that were not agreed with the manufacturer
- use of replacement or wear parts that were not approved by the manufacturer
- operating the pump group outdoors (parts and components are not UV resistant)

2.5 Responsibilities of the operator

The operator must ensure that:

- the pump group is only used for its intended purpose
- the pump group is installed, operated and maintained according to the specifications in the Installation and Operating Manual
- the pump group is only operated according to local regulations and occupational health and safety regulations
- all precautionary measures have been carried out to avoid dangers originating from the pump group
- all precautionary measures for first aid treatment and firefighting have been carried out
- only authorized and trained users have access to the pump group and operate it
- users have access to this Installation and Operating Manual at all times

2.6 Groups of persons

Only qualified persons may operate the pump group or perform service and maintenance work.

User

A user is deemed to be qualified if they have read these operating instructions and understood the potential risks associated with incorrect behavior.

Fitter/commissioner

Due to their specialist training and knowledge, and taking into consideration the applicable standards, provisions, regulations and laws, a fitter/commissioner is capable of performing work on the pump group and recognizing and avoiding potential risks.

3 Technical data

Hydraulic performance data	
Max. operating pressure	6 bar
Ambient temperature	-2 °C to +40 °C (observe pump specification!)
Operating temperature	+2 °C to +90 °C (observe pump specification!)
Opening pressure of gravity brake	10 mbar
Kvs bypass	6.3
Temperature display area	0 - 120 °C
Temperature setting area	20 - 80 °C
Media	Water / water-glycol mixtures according to VDI 2035/ÖNORM H 5195
Electrical connection	
Power supply	See separate pump documentation!
Dimensions	
Width x height x depth with EPP shell	300x370x240 mm
Axis center distance	125 mm
Sealing surfaces distance	342.5 mm
Connections to pipe network	
Heating circuit (top)	1½" AG male connection; flat sealing. Fitting 1½" Union nut x 1" IG female connection
Boiler circuit (bottom)	1½" male connection; flat sealing
Tightening torques for screwed connections	
¾"	35 Nm
1"	55 Nm
1¼"	90 Nm
1½"	130 Nm
Material	
Fittings	brass CW617N
Pipes	galvanized steel Ø48 mm
Plastics	impact resistant and temperature resistant
Flat seals	AFM 34/2
Bypass pipe	brass CW617N
Gravity brake	POM. NBR. stainless steel
O-rings	EPDM
Insulation	EPP
Wall bracket	Galvanized steel sheet
Circulation pump	
The technical data on the circulating pumps can be found in the respective pump documentation.	
Motor incl. controller	
The technical data on the motors can be found in the respective motor documentation.	

4 Pressure loss curve

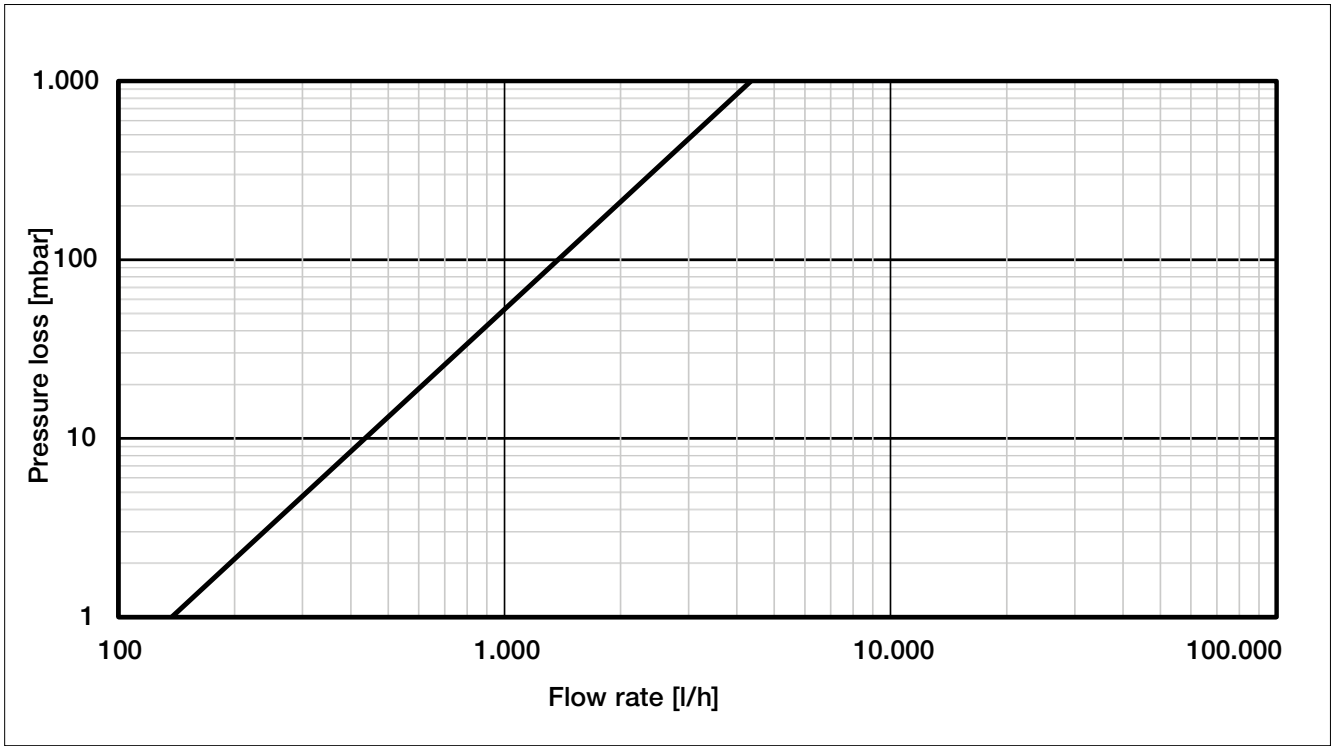

5 Overall dimensions

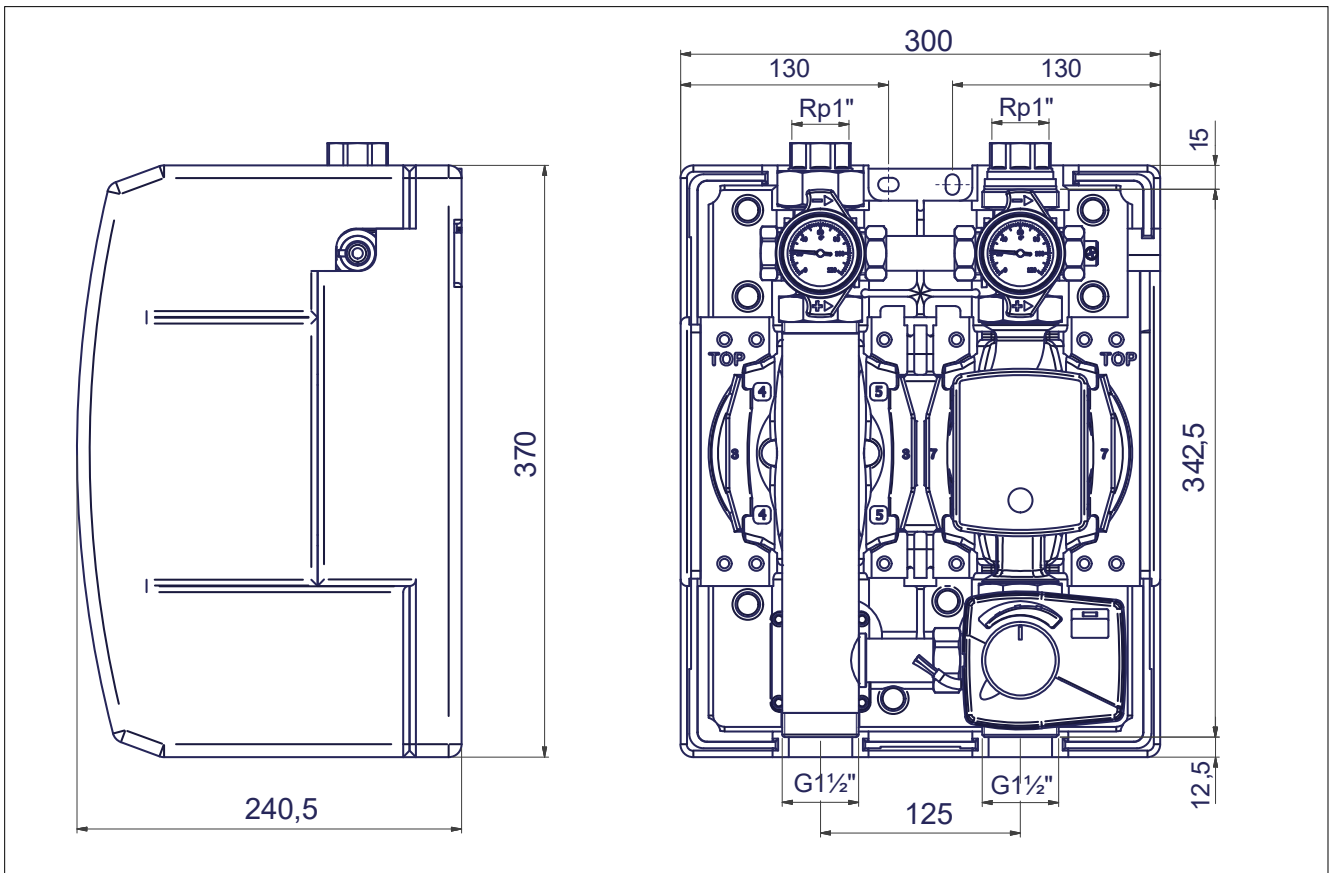

6 Components overview

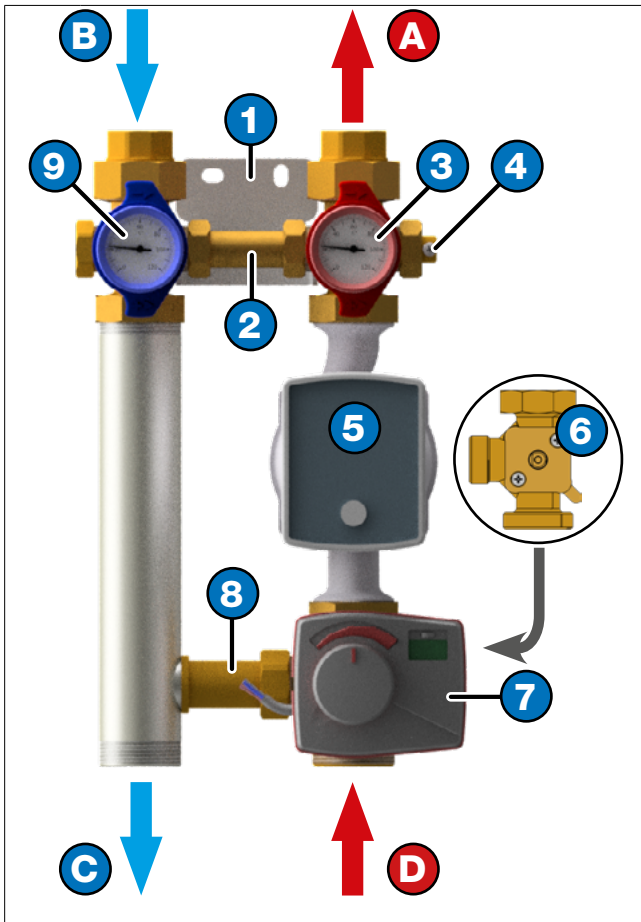

- 1 Wall bracket
- 2 Distance pipe
- 3 Ball valve with gravity brake ¹⁾ (supply)
- 4 Immersion sleeve for supply sensor of the motor
- 5 Circulation pump
- 6 3-way-mixer
- 7 Motor incl. controller
- 8 Bypass connection pipe
- 9 Ball valve (return)
- A Supply outlet (heating circuit)
- B Return inlet (heating circuit)
- C Return outlet (boiler circuit)
- D Supply inlet (boiler circuit)

1) See 7.4 „Thermometer handle position“ on page 7

7 Installation and commissioning

⚠ DANGER Electricity!

Risk of death from electric shock.

- Work on parts carrying live voltage must only be carried out by trained electricians.
- Disconnect the power supply of the system and secure it against being switched back on before carrying out any installation, maintenance, cleaning or repair work.

NOTICE The installation and commissioning of the pump group must only be carried out by trained personnel who have been authorized by the manufacturer.

⚠ CAUTION Take care to adhere to the specified installation positions and flow directions of the individual components to be replaced during repair or replacement work!

⚠ CAUTION Material damage!
A water hammer may occur if the stop valve is opened quickly.

- Always open the stop valve slowly and in a controlled way.

7.1 Installation diagram

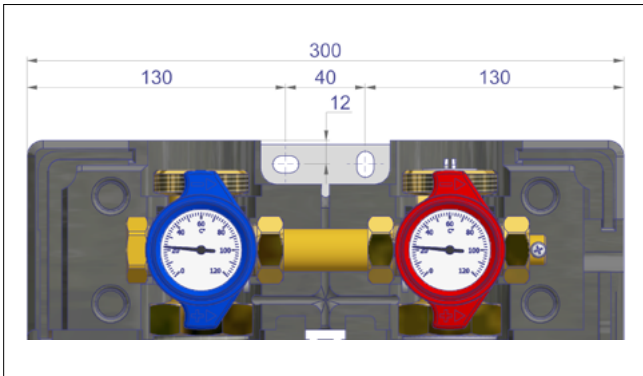

7.2 Installation

All screw fittings must be checked and tightened if required prior to installation and commissioning!

Torque:

- 3/4" fittings 35 Nm
- 1" fittings 55 Nm
- 1 1/4" fittings 90 Nm
- 1 1/2" fittings 130 Nm

Requirement

- The valves are pre-installed at the factory but must be checked for leaks during commissioning (pressure test).
1. Dismantle the front panel of the pump group.

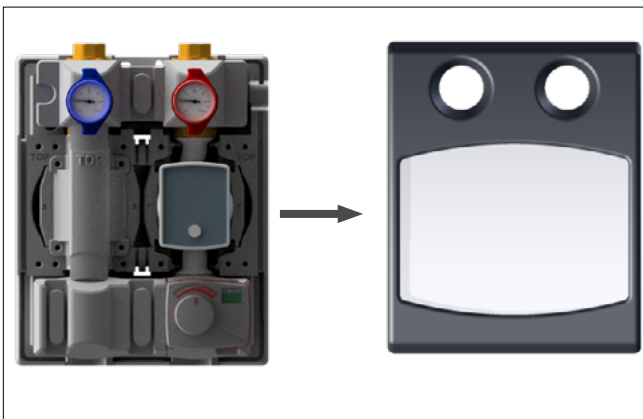

2. Mark the drilling points for installing pump group.
3. Drill the holes corresponding to the screw and anchor size.
4. Place the anchor.
5. Screw the screws into the anchor.
6. Place the pump group to the wall in a vertical installation position (see 7.1 Installation diagram).
7. Screw the screws into the anchor.
8. Remove the thermometer handles and dismantle the intermediate insulation.
9. Connect the supply and return lines and check that all screw connections are tight.

7.3 Initial commissioning

Requirement

- The pump group is completely assembled.

Connection of the power supply

1. Connect the power supply (see separate pump documentation).
- ✓ **The pump group switches on automatically after being connected to the power supply.**
2. Vent the heating system.

NOTICE

The pump group must be switched off during the ventilation process!

3. Mount intermediate insulation and attach thermometer grips.
4. Mount the front panel of the pump group.

Settings of the motor and controller

Set-point temperature is preset to 50 °C.

- ✓ **For further information on the motor and controller, please refer to the enclosed instructions.**

7.4 Thermometer handle position

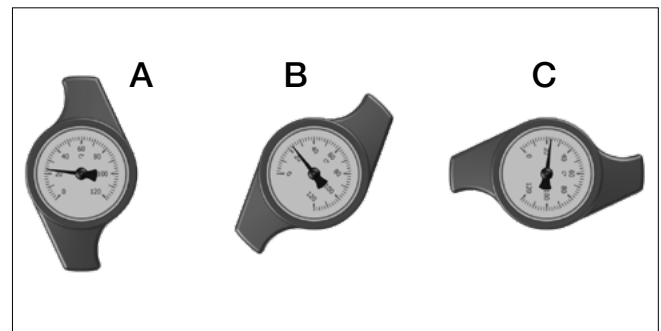

- A Operation position: Gravity brake ready to work; ball valve open
- B Empty: Gravity brake open; ball valve 1/2 open (only included in the supply line)
- C Service position: Ball valve closed

7.5 Exchanging the supply and return line

Initial situation:

The supply line is on the right side.

✓ Disconnect the power supply and secure it against being switched on again.

1. Disassemble the upper fittings.
2. Loosen the nuts on the pump bottom connection and remove the distance tube.
3. Turn the pump and the flow ball valve by 180 degrees.

4. Rotate the nut on the return ball valve and turn it by 180 degrees. Remove the motor from the 3-way mixing valve.

5. Rotate the pump group by 180 degrees and tighten all connections and fittings.

The supply line is now on the left side.

6. Realign the mixer plug and mount the motor.

✓ Observe the separate operating instructions of the motor.

✓ Check the pump group for leaks.

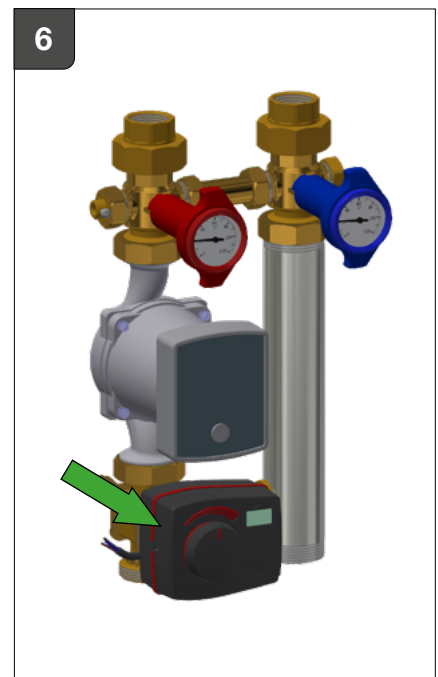
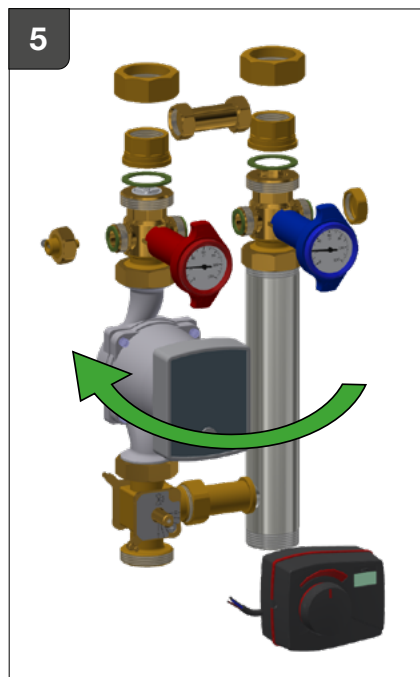
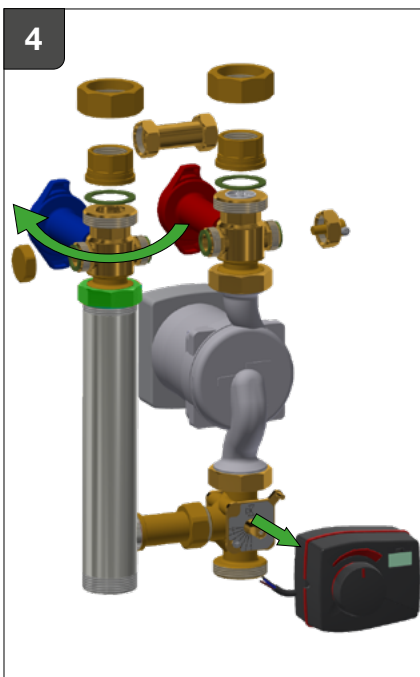
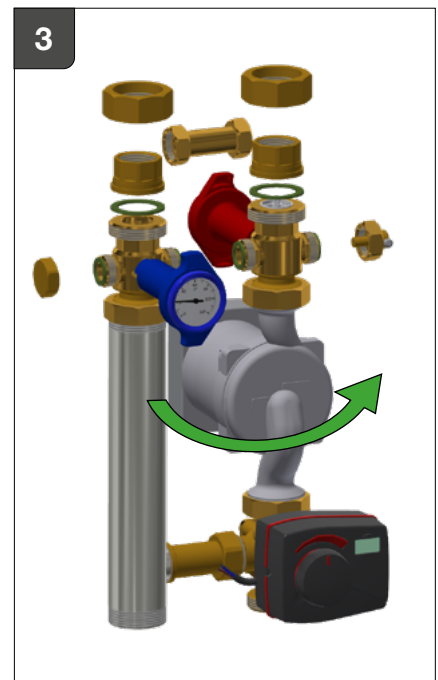
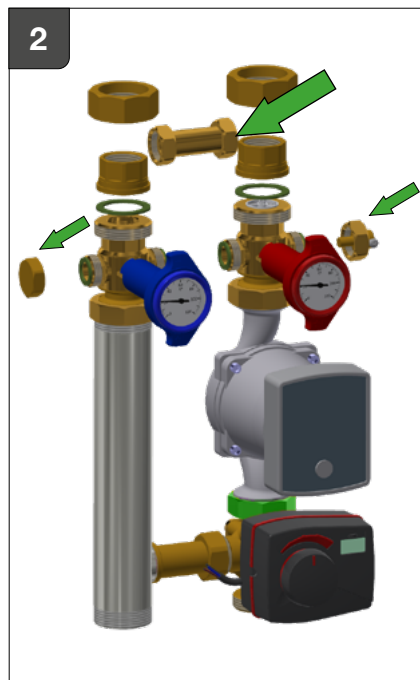
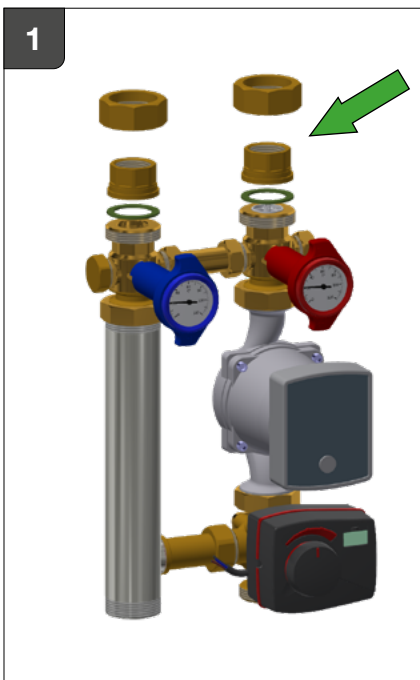

8 Maintenance

⚠ DANGER

Electricity!

Only perform maintenance work on the pump group if the voltage supply has been disconnected.

⚠ WARNING

Hot water!

Severe scalds possible.

Do not reach into the hot water when emptying the pump group.

Ensure that the pump group has cooled down before carrying out maintenance, cleaning and repair work.

Install a suitable scald protection device at every tapping point (for example, safety shut-off valve or thermostat mixer tap).

More detailed information on scald protection can be found in DIN 1988, sheet 2, clause 4.2.

⚠ WARNING

Hot surfaces!

Serious burns possible.

Do not touch the pipelines or the components during operation.

Ensure that the pump group has cooled down before carrying out maintenance, cleaning and repair work.

Wear heat-resistant safety gloves if it is necessary to carry out work on hot components.

NOTICE

The maintenance of the pump group must only be carried out by trained personnel who have been authorized by the manufacturer.

8.1 Annual maintenance intervals

1. General visual inspections

- Check the station for leaks and retighten sealing connections or replace seals, as required.

2. Functional checks

- Check that settings and operating and performance parameters are set correctly.
- Check flow noise during operation.
- Ask users if there are any noticeable problems.

3. Ball taps

- Check that stop valves and ball taps can move freely.

4. Pump

- Pay attention to the noise of the pump.

5. 3-way mixer

- Check 3-way mixer for function.

6. Motor incl. controller

- Check the motor for function.

7. Actions following maintenance work

- Check that all screw fittings that were unscrewed have been retightened and retighten if necessary.
- Remove all tools, materials and other equipment used from the working area.
- Vent the system.

8.2 Replacement of wear parts

Please note that the pump group contains parts that, for technical reasons, are subject to wear depending on the intensity of use, even if the specified care and maintenance have been observed.

This especially applies to mechanical parts and parts that could come into contact with water and steam, for example, hoses, seals, valves, etc.

By their nature, defects as the result of wear do not represent a fault and therefore are not covered by the warranty or the guarantee. Nevertheless, these defects and malfunctions must only be remedied by trained specialist personnel.

Contact your specialist dealer for this.

8.3 Disassembling the circulation pump

1. Disconnect the power supply and secure it against being switched on again.
2. Remove the front panel of the pump group.
3. Close all stop valves.
4. Disassemble thermometer handles and intermediate insulation.

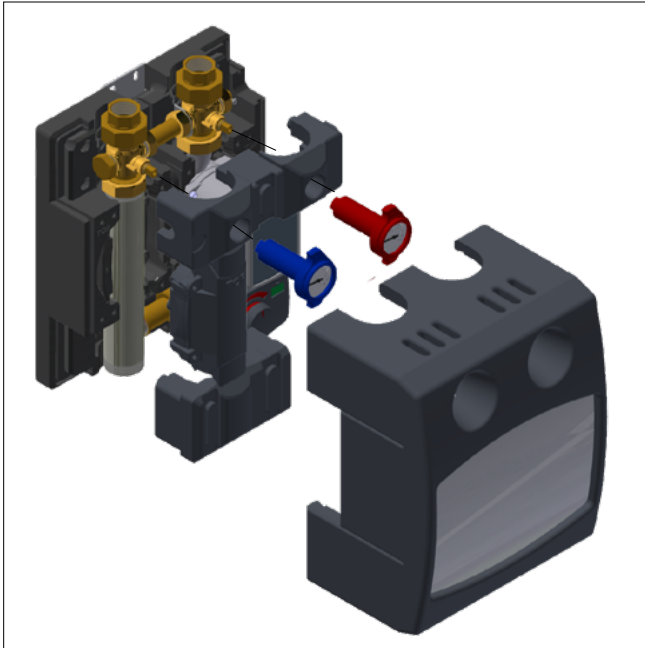

5. Disconnect the wiring of the circulation pump.
6. Release the fastening nuts (X) and remove the circulation pump.

⚠ WARNING Risk of heavy scalding from hot water!

- Allow the pump group to cool before servicing.
- Do not reach into the hot medium when emptying.

8.4 Installation of the circulation pump

1. Replace damaged or defective seals if necessary.
2. Insert the circulation pump and tighten the nuts (X) (for tightening torques see "Technical data" on page 4).
3. Connect the wiring of the circulation pump.
4. Slowly open the ball valves by turning the thermometer handle.
5. Slowly pressurize the pump assembly and vent the system if necessary.
6. Check the pump group for leaks.
7. Restore the power supply to the pump group.
8. Disassemble the thermometer handles.
9. Install the intermediate insulation, the thermometer handles, and the front panel.

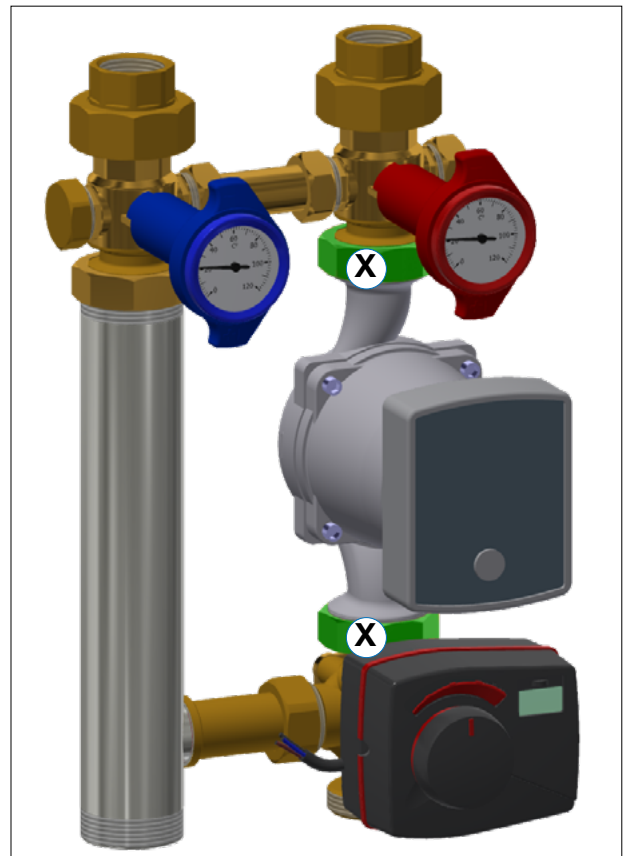

8.5 Disassembling the 3-way mixer

1. Disconnect the power supply and secure it against being switched on again.
2. Remove the front panel of the pump group.
3. Close all stop valves.
4. Disassemble thermometer handles and intermediate insulation.

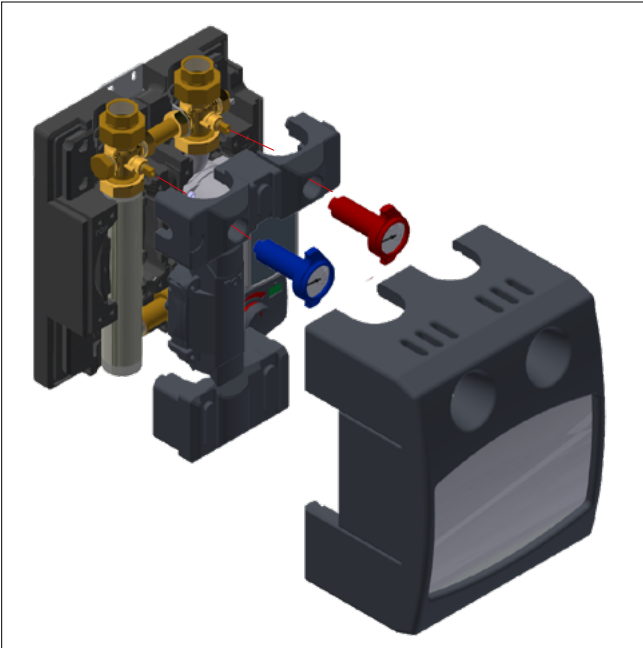

5. Move the mixer rotary plug valve to center position by manual adjustment of the motor.
 6. Disassemble the motor (Pos. B, the assembly/disassembly of the motor can be found in the respective manufacturer's instructions).
 7. Remove the mixer (pos. A) by loosening the union nuts.
- ✓ **The assembly / disassembly of the motor can be found in the respective manufacturer's manual.**

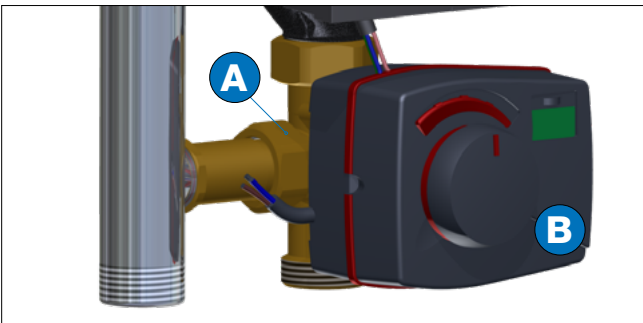

8.6 Installing the 3-way mixer

1. Replace damaged or defective seals if necessary.
 2. Install the 3-way mixer (B) and tighten the union nuts (for tightening torques see "Technical data" on page 4).
 3. Mount the motor (A).
 4. Slowly open the ball valves by turning the thermometer handle.
 5. Restore the power supply to the pump group.
 6. Disassemble the thermometer handles.
 7. Install the intermediate insulation, the thermometer handles, and the front panel.
- ✓ **The assembly / disassembly of the motor can be found in the respective manufacturer's manual.**

8.7 3-way mixer motor setting

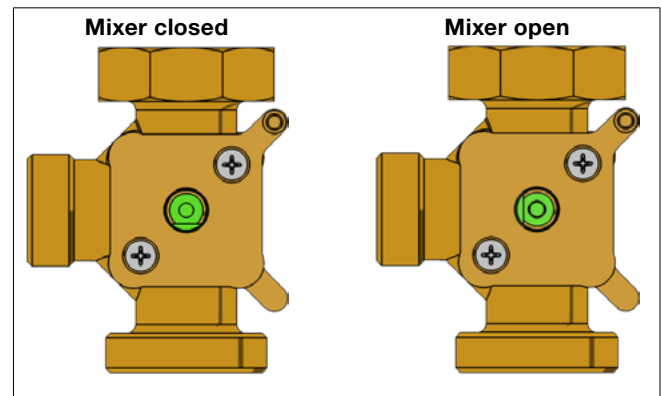

9 Disposal

▲ WARNING Potential contamination of the environment and groundwater due to improper disposal!

The regulations and guidelines of the legislature in the country of operation must be complied with when disposing of components and operating materials.

1. Ensure that all subassemblies and components are de-energized.
2. Professionally disassemble the pump group or commission a specialist company with this task.
3. Sort the subassemblies and component parts into recyclable materials and operating materials.
4. Dispose of the subassemblies and components according to regional laws and regulations or take them to be recycled.

9.1 Return shipment to the manufacturer

Get in contact with the manufacturer if you would like to return the pump group or parts of it.

9.2 Reporting to administrative bodies and manufacturer

Inform the manufacturer about decommissioning and disposal of the pump group for statistical purposes.

10 Guarantee

WATTS products are extensively tested. For this reason, WATTS only guarantees the replacement or – at the exclusive discretion of WATTS – free-of-charge repair of the components of the supplied products that, in the opinion of WATTS, have verifiable manufacturing faults. Warranty claims due to defects or defects of title can be invoked within one (1) year from delivery/transfer of risk. Excluded from the warranty are damages attributable to normal product wear or friction as well as damages as a result of modifications or non-authorized repairs on the products, for which WATTS rejects all claims for compensation (direct or indirect). (For more detailed information, please refer to our website.) All deliveries are subject to the General Terms and Conditions, which can be found on www.wattswater.eu/gtc/.

The descriptions and photographs contained in this product specification sheet are supplied by way of information only and are not binding.

Watts Industries reserves the right to carry out any technical and design improvements to its products without prior notice."

Warranty: All sales and contracts for sale are expressly conditioned on the buyer's assent to Watts terms and conditions found on its website at www.wattswater.eu/gtc/

Watts hereby objects to any term, different from or additional to Watts terms, contained in any buyer communication in any form, unless agreed to in a writing signed by an officer of Watts..



Watts Industries Deutschland GmbH

Godramsteiner Hauptstr. 167 • 76829 Landau • Deutschland

Tel. +49 6341 9656 0 • Fax +49 6341 9656 560

WIDE@wattswater.com • www.wattswater.de