

DS Series

Magnetic dirt separator

Technical Data Sheet



Description

WCS, WSS and WBS Series magnetic dirt separators ensure long-term efficient boiler operation by preventing the adverse effects caused by residues of soil, limescale, sand and ferrous metals.



WCS-Compact Magnetic Dirt Separator

Dirt separator complete with removable external magnet for continuous separation of metallic and non-metallic sludge and debris in heating and cooling systems. Can be fitted vertically, horizontally or diagonally. Brass body. Complete with drain valve for cleaning. Available with 3/4" and 1" connections. EPP rigid foam insulation as per AnIV and EnEV requirements: available to order.

Part No.	DN	Max. flow rate/PN
DSC0034W	3/4"	1.30 m ³ /h - PN10
DSC0100W	1"	2.00 m ³ /h - PN10



WSS-Threaded magnetic dirt separator

Dirt separator complete with removable external magnet for continuous separation of metallic and non-metallic sludge and debris in heating and cooling systems. Can be fitted vertically, horizontally or diagonally. Brass body. Complete with drain valve for cleaning. Available with 3/4" and 2" threaded connections. EPP rigid foam insulation as per AnIV and EnEV requirements: available to order.

Part No.	DN	Max. flow rate/PN
DST0034W	3/4"	1.30 m ³ /h - PN 6
DST0100W	1"	2.00 m ³ /h - PN 6
DST0112W	1 1/2"	5.00 m ³ /h - PN 10
DST0200W	2"	7.50 m ³ /h - PN 10



WBS-Flanged magnetic dirt separator

Dirt separator complete with magnet for continuous separation of metallic and non-metallic sludge and debris in heating and cooling systems. With magnet fitted inside the dry-pocket (1 magnet in one pocket from DN65 to DN150, 2 magnets in 2 pockets in DN200, DN250 and DN300), designed for rapid removal of metal particles by means of a flexible mechanism, without increasing the installation height. Available with flanged connections (PN16) from DN65 to DN200. Can be connected horizontally. Steel body. EPP rigid foam insulation up to DN100 as per AnIV and EnEV requirements: available to order.

Part No.	DN	Max. flow rate/PN
DSF0065W	DN65	20.00 m ³ /h - PN 10
DSF0080W	DN80	27.00 m ³ /h - PN 10
DSF0100W	DN100	47.00 m ³ /h - PN 10
DSF0125W	DN125	72.00 m ³ /h - PN 10
DSF0150W	DN150	108.00 m ³ /h - PN 10
DSF0200W	DN200	180.00 m ³ /h - PN 10
DSF0250W	DN250	288.00 m ³ /h - PN 10
DSF0300W	DN300	405.00 m ³ /h - PN 10

	WCS	WSS	WBS
Water with glycol	Max. 50%50%	Max. 50%50%	Max. 50%50%
Body	Brass	Brass	ST37.2 steel
Separation	To 5µm	To 5µm	To 5µm
PN	10	10	10
Max. temperature	110°C	110°C	110°C
Warranty	20 years ≤ 110°C 5 years > 110°C	20 years ≤ 110°C 5 years > 110°C	5 years

WCS Series

DN	¾"	1"
Installation width (mm)	100	100
Max. flow rate - m ³ /h	1.30	2.00
Dp for Max. flow rate - kPa	1.90	2.70
Water content (l)	0.23	0.33
Weight (kg)	1.35	1.63
Magnet	1	1

WSS Series

DN	¾"	1"	1 ½"	2"
Installation width (mm)	90	90	128	128
Max. Flow rate - m ³ /h	1.3	2.0	5.0	7.5
Dp for Max. flow rate - kPa	2.1	3.8	2.6	5.8
Water content (l)	0.40	0.40	0.80	0.80
Weight (kg)	2.2	2.3	3.70	3.90
PN	10	10	10	10
Magnet	1	1	1	1

WBS Series

DN	65 PN16	80 PN16	100 PN16	125 PN16	150 PN16	200 PN16	250 PN16	300 PN16
Installation width (mm)	350	470	475	635	635	775	890	1005
Max. flow rate - m ³ /h	20	27	47	72	108	180	288	405
Dp for Max. flow rate - kPa	2,9	3,1	3,7	4,2	4,9	5,8	7,0	7,8
Water content (l)	5	17	17	50	50	105	210	350
Water content (l)	14	24	28	58	61	107	162	261
Magnet	1	1	1	1	1	2	2	2

Not suitable for demineralised water, potable water or hazardous or flammable substances. Can be used in conjunction with approved chemicals/inhibitors in accordance with local regulatory requirements. Make sure the dirt separator is compatible with the materials used in the construction of the system. On flanged models, the maximum operating pressure is 10 bar (PN10), whereas the flanged connections are PN16.

Application

The use of magnetic dirt separators in heating systems is essential to ensure long-term efficient boiler operation by preventing the adverse effects caused by residues of soil, limescale, sand and ferrous metals found not only in older but also in new systems. The water flow enters the dirt separator, where the cyclonic motion helps separate the dirt, which is heavier. The magnet retains most of the metallic debris. The magnet is always installed, positioned and protected in such a way that it does not come into contact with the water. Both metallic and soil residues are then expelled through the drain valve, once the permanent magnet not in direct contact with the liquid is switched off.

Installation

The dirt separator must be installed on the return circuit, upstream of the boiler, to protect the boiler against debris in the piping, especially during system start-up. The dirt separator should be installed upstream of the pump, always in a vertical position. For the **WBS flanged Series**, leave at least 15 cm of clearance below the dirt separator to allow removal of the magnet.

Overall dimensions (mm)

WCS and WSS Series

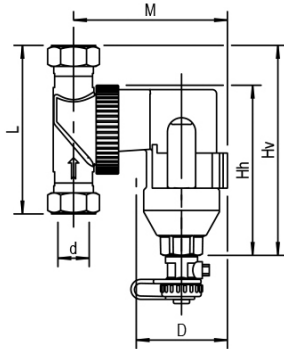

WSS Series

DN	3/4"	1"	1 1/2"	2"
Hv (mm)	162	162	224	224
Hh (mm)	149	149	210	210
L (mm)	90	90	128	128
M (mm)	125	129	141	148

WCS Series

DN	3/4"	1"
Hv (mm)	140	140
Hh (mm)	121	121
L (mm)	100	100
M (mm)	112	124
D (mm)	73	83

WBS Series

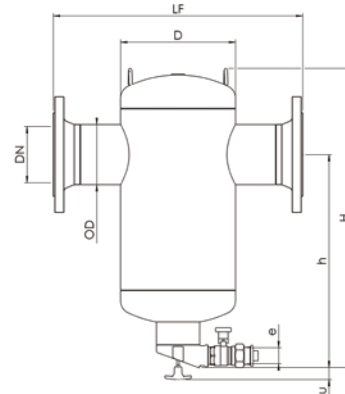

WBS 200, 250 - 300

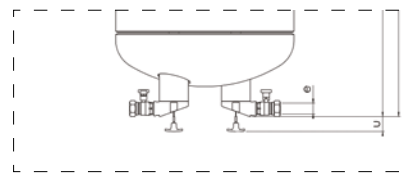

WBS Series

DN	65	80	100	125	150	200	250	300
OD (mm)	76.1	88.9	114.3	139.7	168.3	219.1	273	323.9
D (mm)	159	219	219	324	324	406	508	610
LF (mm)	350	470	475	635	635	775	890	1005
H (mm)	471	576	576	798	798	1063	1264	1492
h (mm)	333	424	412	605	591	773	896	1058
e (mm)	RP1	RP1	RP1	RP1	RP1	RP1	RP2	RP2

Specification text

WCS Series (compact). Dirt separator with magnet **WCS Series** WATTS brand. 3/4" and 1" angle-adjustable connections. Brass drain valve. Brass body and fittings. Usable fluids: water and glycol solutions; maximum glycol content 50%. Maximum operating pressure: 10 bar. Operating temperature range 0÷110°C. Particle separation capacity: to 5 microns.

WSS Series (threaded). Dirt separator with magnet **WSS Series** WATTS brand. 3/4", 1", 1 1/2", 2" angle-adjustable connections. Brass drain valve. Brass body and fittings. Usable fluids: water and glycol solutions; maximum glycol content 50%. Maximum operating pressure: 6 bar for 3/4" and 1" connections; 10 bar for 1 1/2" and 2" models. Operating temperature range 0÷110°C. Particle separation capacity: to 5 microns.

WBS Series (flanged). Dirt separator with magnet **WBS Series** WATTS brand. Flanged connections from DN 65 to DN 200. 1 magnet in sealed chamber from DN65 to DN150. 2 magnets in 2 sealed chambers on DN200. Painted steel body. Usable fluids: water and glycol solutions; maximum glycol content 50%. Maximum operating pressure 10 bar. Operating temperature range 0÷110°C. Particle separation capacity: to 5 microns.

The descriptions and photographs contained in this product specification sheet are supplied by way of information only and are not binding.

Watts Industries reserves the right to carry out any technical and design improvements to its products without prior notice. Warranty: All sales and contracts for sale are expressly conditioned on the buyer's assent to Watts terms and conditions found on its website at www.wattswater.eu. Watts hereby objects to any term, different from or additional to Watts terms, contained in any buyer communication in any form, unless agreed to in a writing signed by an officer of Watts.

WATTS®



Watts Industries Italia S.r.l.

Via Brenno, 21 • 20853 Biassono (MB) • Italy
Tel. +39 039 4986.1 • Fax +39 039 4986.222
infowattsitalia@wattswater.com • www.watts.com