

Job Name _____

Contractor _____

Job Location _____

Approval _____

Engineer _____

Contractor's P.O. No. _____

Approval _____

Representative _____

LEAD FREE*

Series 405-NRS-RW Non-Rising Stem, Resilient Wedge, Flanged Gate Valves

Sizes 2" – 12" – Epoxy Coated

Series 405-NRS-RW Non-Rising Stem Resilient Wedge Gate Valves are available in sizes 2"-12" flanged by flanged and 2½"-10" flanged by grooved configurations. The valve body is epoxy coated internally and externally. The valve is operated by a Handwheel or a valve key. The resilient wedge disc design offers both positive seating and resistance against high differential pressure. The Series 405-NRS-RW is best suited for service in either the fully open or closed position but is suitable for use as a throttling valve. This series is recommended for irrigation, potable water, water distribution service, feed lines and sewage disposal facilities.

Features

- ASTM A126 Class B Iron (Flanged x Flanged)
- ASTM A536 65-45-12 Ductile Iron (Flanged x Groove)
- Full port flow, low head loss
- Epoxy coated, internal and external
- Vulcanized encapsulated resilient wedge
- In-line serviceable
- Boss-tapped and plugged
- MSS-SP-70 conformance

Specifications

Flanged by flanged valve bodies shall comply with ASTM A126; flanged by grooved valve bodies shall comply with ASTM A536. Valve shall be pressure rated to 200psi (14 bars) CWP with an operating temperature up 140°F. Valve shall have a non-rising stem, full port flow and epoxy coated. Valve shall be a Watts Series 405-NRS-RW.

NOTICE

The information contained herein is not intended to replace the full product installation and safety information available or the experience of a trained product installer. You are required to thoroughly read all installation instructions and product safety information before beginning the installation of this product.



6" 405-NRS-RW

Standards

Face-to-face dimension shall comply with ASME B16.10 Class 125 cast iron flanged valves. Flange end connection shall comply with ASME B16.1 Class 125 & AWWA Class D. Flanges are flat faced and smooth finished. Grooved end connection shall comply with AWWA C515 & C606.

Configuration

Flanged x Flanged (AWWA C509): Available size 2"-12"

Flanged x Grooved (AWWA C515): Available size 2½"-10"

Pressure - Temperature

200psi (14 bar) CWP

Maximum Temperature: 140°F (60°C)

*The wetted surface of this product contacted by consumable water contains less than 0.25% of lead by weight.

Watts product specifications in U.S. customary units and metric are approximate and are provided for reference only. For precise measurements, please contact Watts Technical Service. Watts reserves the right to change or modify product design, construction, specifications, or materials without prior notice and without incurring any obligation to make such changes and modifications on Watts products previously or subsequently sold.

WATTS®

Parts - Materials

NO.	PARTS	MATERIAL	ASTM DESIGNATION
1	*Body (FxF)	Cast Iron	A126 Class B
	*Body (FxG)	Ductile Iron	A536 65-45-12
2	Bonnet	Cast Iron	A126 Class B
3	Wedge	Cast Iron & Rubber (EDPM)	A126 Class B
4	Hand Wheel	Cast Iron	A126 Class B
5	Stem	Stainless Steel	A276 Type 304
6	Stuffing Box	Cast Iron	A126 Class B
7	O-ring A	Rubber	D2000AA6014
8	O-ring B	Rubber	D2000AA6014
9	Bonnet Gasket	Rubber	D2000AA6014
10	Stem Nut	Bronze	B62
11	Wiper Ring	Rubber	D2000AA6014
12	Bonnet Bolt & Nut	Steel	A307 Grade B
13	Stud & Nut	Steel	A307 Grade B
14	Hand Wheel Washer	Steel	A307 Grade B
15	Top Nut	Steel	A307 Grade B
16	TAP Plug	Bronze	B62

*Body Configuration: FxF - Flanged by Flanged, FxG - Flanged by Grooved

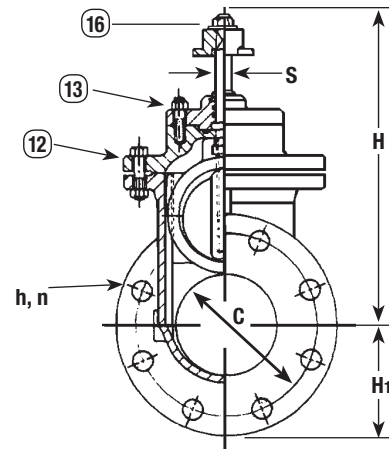
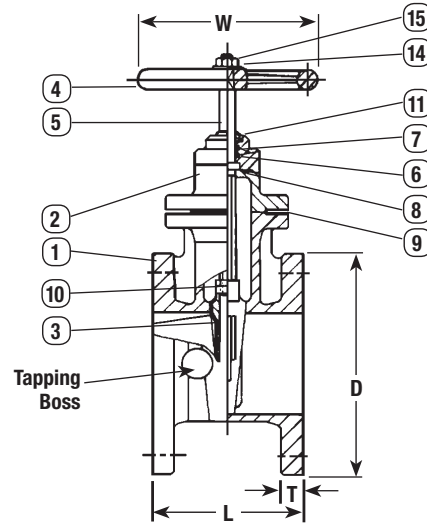

Dimensions - Weights

SIZE	FLANGE DIMENSIONS										405 (FXF)		405 (FXG)												
	L		D		C		BOLT HOLES		T		W		H (NRS)		H1		S		WEIGHT						
in.	in.	mm	in.	mm	in.	mm	in.	mm	# of Holes	in.	mm	in.	mm	in.	mm	in.	mm	in.	mm	in.	mm	lbs.	kgs.	lbs.	kgs.
2	7	178	6	152	4 ³ / ₄	121	3 ³ / ₄	19	4	5 ⁵ / ₈	16	7 ¹ / ₁₆	179	7 ¹⁵ / ₁₆	230	3	76	5 ⁵ / ₈	16	22	10	—	—		
2 ¹ / ₂	7 ¹ / ₂	191	7	178	5 ¹ / ₂	140	3 ³ / ₄	19	4	1 ¹ / ₁₆	18	7 ¹ / ₁₆	179	9 ¹ / ₁₆	259	3 ¹ / ₂	89	5 ⁵ / ₈	16	29	13	26	12		
3	8	200	7 ¹ / ₂	191	6	152	3 ³ / ₄	19	4	3 ³ / ₄	19	7 ⁷ / ₈	200	10 ¹ / ₄	289	3 ³ / ₄	95	1 ¹ / ₁₆	18	40	18	37	17		
4	9	229	9	229	7 ¹ / ₂	191	3 ³ / ₄	19	8	1 ⁵ / ₁₆	24	8 ¹³ / ₁₆	224	12 ¹ / ₂	352	4 ¹ / ₂	114	1 ⁹ / ₁₆	21	62	28	57	26		
6	10 ¹ / ₂	267	11	279	9 ¹ / ₂	241	7 ⁷ / ₈	22	8	1	25	11	279	16 ¹³ / ₁₆	470	5 ¹ / ₂	140	1 ⁵ / ₁₆	24	111	50	106	48		
8	11 ¹ / ₂	292	13 ¹ / ₂	343	11 ³ / ₄	298	7 ⁷ / ₈	22	8	1 ¹ / ₈	29	11	279	20 ⁷ / ₈	575	6 ³ / ₄	171	1	25	194	88	189	86		
10	13	330	16	406	14 ¹ / ₄	362	1	25	12	1 ¹ / ₁₆	30	12 ⁷ / ₁₆	316	23 ⁷ / ₈	657	8	203	1 ¹ / ₄	32	272	123	267	121		
12	14	356	19	483	17	432	1	25	12	1 ¹ / ₄	32	14	356	28 ³ / ₁₆	773	9 ¹ / ₂	241	1 ¹ / ₄	32	383	174	—	—		



USA: T: (978) 689-6066 • F: (978) 975-8350 • Watts.com
 Canada: T: (905) 332-4090 • F: (905) 332-7068 • Watts.ca
 Latin America: T: (52) 81-1001-8600 • Watts.com